

# WDRA

WORLD DRAG RACING ALLIANCE

2024 WORLD CHAMPION



**WDRA**  
Summit RACING EQUIPMENT  
WORLD CHAMPIONSHIP  
presented by SUNCOAST

**WDRA**  
WORLD DRAG RACING ALLIANCE  
SUMMIT SPORTSMAN DRAG RACING SERIES  
2024 JUNIOR  
WORLD CHAMPION

Evan Muchler

2025 RULEBOOK  
WORLD CHAMPIONS EDITION



## ***Winning Takes Work. Getting Parts is Easy.***

*Get the performance you want—and solid value for your hard-earned money—at Summit Racing Equipment. Call or visit us online today and see why we've been The World's Speed Shop® since 1968!*

- *The largest inventory of performance and racing parts in the country*
- *Fast same-day shipping on orders for in-stock parts placed by 10 pm EST*
- *Guaranteed low prices every day*
- *Number One-rated customer service and technical support*

## ***SummitRacing.com is Your Online Performance Shop!***

- *Huge online catalog featuring millions of parts*
- *Savings Central—special offers, rebates, sales, clearance items, and more*
- *Track orders, ask tech questions, and much more!*
- *Shop anytime with the Summit Racing Mobile App*

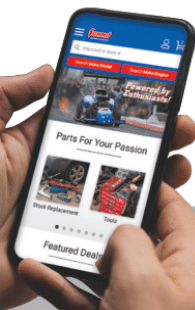

***SummitRacing.com®***

# WDRA

## WORLD DRAG RACING ALLIANCE



**OUR MISSION:** *To provide value as a sanctioning body to racers and facilities through process modernization, unparalleled service and value driven partnerships.*

www.racewdra.com  
 Facebook @worlddragracingalliance  
 Instagram @racewdra

PO Box 701  
 Norwalk, OH 44857  
 Info@racewdra.com

**The Ones Who Get Thanked or Yelled At:**

Jon O'Neal  
 Frank Kohutek  
 Skooter Peaco  
 Josh Peake

Jon@racewdra.com  
 Frank@racewdra.com  
 Skooter@racewdra.com  
 Josh@racewdra.com

**The Don**

Don Scott

Don.scott@racewdra.com

**The Membership Queen:**

Donna Harper

Membership@racewdra.com

**PR Super Star:**

Jessica Hicks Spears

Jess@racewdra.com

**The Fixers Of What We Break:**

Todd & Laurie Silvey

WDRA Website & IT

**Our One Phone Call:**

Chuck Haubiel

Law Offices Of Charles Haubiel

**Keeps Us Out Of IRS Jail:**

Judy Mosher / Jackie Maike

Payne, Nickels & Company CPA

**The A Team:** Lisa Harris, Tammy Kohutek, Kim, Barry & Brittany Werner, Bill Northup, Chuck Turocy, Monte Caldarelli, John & Donna Vogel, Bryan Epps (BME Photography), Renee Bingham (God Speed Ministry)

# TABLE OF CONTENTS

|   |       |
|---|-------|
| <b>HOW TO USE THIS BOOK</b>                 | Pg 4  |
| <b>WDRA BRACKET PROGRAMS</b>                |       |
| Summit Sportsman Drag Racing Series         | Pg 6  |
| Summit World Championship                   | Pg 7  |
| Summit Bracket Finals                       | Pg 8  |
| Teen Racing                                 | Pg 9  |
| Junior Dragster                             | Pg 11 |
| Factory Street                              | Pg 20 |
| <b>ELAPSED TIME SPECIFIC RULES</b>          | Pg 22 |
| <b>ELECTRIC VEHICLES</b>                    | Pg 26 |
| <b>MOTORCYCLE</b>                           | Pg 29 |
| <b>SNOWMOBILE</b>                           | Pg 29 |
| <b>ATV/UTV</b>                              | Pg 30 |
| <b>SPECIAL VEHICLES</b>                     | Pg 32 |
| <b>GENERAL TECHNICAL REGULATIONS</b>        | Pg 34 |
| <b>CHASSIS CERTIFICATION AND INSPECTION</b> | Pg 47 |
| <b>GENERAL RACE REGULATIONS</b>             | Pg 49 |
| Pit Area Rules                              | Pg 53 |
| Interpretation of Rules                     | Pg 53 |
| SFI Specifications                          | Pg 54 |
| <b>Grounds For Disqualification</b>         | Pg 56 |
| <b>Technical Reference Guide</b>            | Pg 56 |



**FROM THE LEADING SUPPORTER OF SPORTSMAN  
DRAG RACING COMES THE NEXT...**

## GAME CHANGER

### **SUMMIT PRO TRAC**

#### **PROFESSIONAL TRACTION COMPOUND**

BY USING SUMMIT'S BUYING AND MARKETING POWER, WE ARE PROUD TO OFFER THIS PREMIUM PRODUCT, WHICH HAS BEEN BLENDED AND PRICED WITH THE RACETRACK OWNER IN MIND. THIS UNIQUE FORMULATION HAS BEEN CREATED, TESTED, AND REFINED BY SOME OF THE BRIGHTEST CHEMISTS AND RACETRACK PREPARATION EXPERTS IN THE RACING INDUSTRY.

- \* PROVIDES MAXIMUM TRACTION IN ALL WEATHER TYPES
- \* PRODUCES MORE WHEEL SPEED FOR IMPROVED ET'S
- \* TRACTION IMPROVES WITH TRAFFIC, GROOVE STAYS STICKY
- \* CAN BE USED FULL STRENGTH OR DILUTED
- \* AVAILABLE FOR PURCHASE IN QUANTITIES AS SMALL AS 2 DRUMS

*Tested & Endorsed by*



# HOW TO USE THIS BOOK

WDR member tracks have agreed to enforce the safety and technical aspects of this rulebook and those may not be changed, waived or altered. A track may have a different race "procedure" than what is outlined in this rulebook at their track (How a buy run is determined, how lane choice is determined, etc.). A track may choose to administer whatever race procedures they see fit. The race procedures, as outlined in this rulebook, will be followed at all WDR managed events. Procedures specific to each of the Summit Bracket Finals events are posted on [racewdr.com](http://racewdr.com) as are the procedures for the Summit World Championships.

It is the racers' responsibility to keep their car legal at all times. Passing tech inspection does not guarantee that the vehicle may not later be found to be in violation of published guidelines. Safety equipment listed within this publication is the minimum requirement. Increased levels of safety equipment and related accessories are always permitted. Guidelines and rules published in this book are effective January 1, 2025, and shall remain in effect until superseded or revised. Revisions during the year will be published on [racewdr.com](http://racewdr.com). All members agree to be bound by WDR's guidelines and rules then in effect.

Any interpretation or deviation of these rules is left to the discretion of WDR officials. Their decision is final. WDR and or its member tracks shall have the authority to impound and retain vehicles and their parts and any other equipment or items that are related to a contestant's participation in an WDR sanctioned event. Such authority shall extend to the investigation of accidents, the testing or inspection of such vehicles, parts, or equipment, or for any other purpose as determined in WDR's sole discretion.

Drag racing is a dangerous sport. There is no such thing as a guaranteed safe drag race. Member hereby assumes full responsibility for and risk of bodily injury, death or property damage due to the negligence of releasees or otherwise while competing, officiating, observing, working for or for any purpose relating to a WDR sanctioned event. If at any time a participant does not accept these risks, the participant agrees not to participate in drag racing

Although WDR works to promote and enhance the safety of the sport, there are no guarantees that such safety measures will ensure safety. Accordingly, in consideration of being granted membership in WDR, the member, for themselves, their personal representatives, heirs, next of kin, successors and assigns, hereby agrees as follows:

- (a) I hereby agree to assume all responsibility and liability for all acts or activities of myself, my drivers, assistants and crew for any and all damage or injury that may be caused by any or all of us by our vehicles, properties or possessions in any way growing out of or resulting from the participation in a WDR sanctioned event.
- (b) I hereby release, waive, discharge and covenant not to sue WDR as an association including its Owners, Directors, Officers, Appointed Officials, Committee Members, Inspectors and volunteer workers assisting in a WDR sanctioned event, all hereinafter referred to as "Releasees" from or for any and all liability to me, my personal representatives, heirs, next of kin, successors and assigns, for all loss or damage for bodily injury, death or damage to property of the undersigned which in any way grows out of or results from any WDR sanctioned event or time trial activity or part thereof, during the sanctioned event and whether any such claim may be based upon alleged active or passive negligence whether caused by the releasee or otherwise, or participation in the wrong, or upon any alleged breach of any statutory duty or obligation.
- (c) I hereby agree to indemnify and save and hold harmless the Releasees and each of them from any loss, liability, damage, or cost they may incur due to the presence of the undersigned in or upon the restricted area or in any way competing, officiating, observing, or working for, or for any purpose participating in the sanctioned event and whether caused by the negligence of the releasees or otherwise.
- (d) I hereby expressly agree that the foregoing release, waiver, and indemnity agreement is intended to be as broad and inclusive as is permitted by the law. Any and all disputes over the terms of this agreement or any claims that the undersigned may make against any of the releasees identified above in paragraph (b) will be filed in and decided by a court of competent jurisdiction in the State of Ohio under the statutory and case law of the State of Ohio. If any portion thereof is held invalid, it is agreed that the balance shall notwithstanding continue in full legal force and effect.
- (e) In consideration of WDR's promotional efforts on behalf of the sport of drag racing, I hereby assign all commercial communication and broadcast rights to WDR and do declare it as my lawful agent and representative regarding such rights. I agree that WDR, or its assigns, on a non-exclusive basis, may use my name and pictures, including pictures of my racing equipment and pictures taken at any WDR sanctioned event for publicity purposes

No liability or duty to third parties, express or implied, is undertaken or assumed by WDR or its Member Tracks regarding any Chassis Certification or any use of a vehicle that contains a certified chassis. Responsibility for the proper construction, rule compliance and performance of a vehicle and its chassis rests with the participant at all times. If injury or death to participant or another person results from operation of the vehicle, participant releases, waives and indemnifies WDR from and against any resulting claim against WDR.



The Laris family has been racing for **30+ years**, and we've been involved in the insurance field for **80+ years**.



We created **Laris Motorsports Insurance** to offer racers broad packaged insurance policies that don't leave gaps in coverage. We offer racers affordable on- and off-track coverage, and we pay contingency!

We provide **excellent customer service, quick turnarounds, and build long-term relationships**. With Laris Motorsports Insurance, you can be confident that you have the **broadest coverage** in the industry!



**SCAN FOR  
QUOTE**

**985-746-4663**

**LARISMOTORSPORTSINSURANCE.COM**





### SUMMIT SPORTSMAN DRAG RACING SERIES (SSDRS)

The Summit Sportsman Drag Racing Series (SSDRS) is the culmination of WDR Member Track Championships and WDR Summit Bracket Finals championships all meeting at the WDR Summit Sportsman Drag Racing Series World Championships.

### SUMMIT SPORTSMAN DRAG RACING SERIES TRACK CHAMPIONSHIP

A racer that meets all SSDRS program requirements can qualify by being the **highest SSDRS qualified racer in track points** at a participating WDR track.

#### ELIGIBILITY REQUIREMENTS:

- Hold a valid WDR license that includes SSDRS registration.
- If you compete in multiple classes, you must register for each class. (one registration per class, per track)
- You may win and qualify at any WDR track.
- Meet requirements for points registration at an SSDRS participating track. SSDRS points begin the day you join WDR online or the postmark date on the mailed in envelope.
- Failure to keep current on SSDRS registration will cause point deductions during the time of expiration when calculating eligibility.
- **Be the highest SSDRS qualified racer in your WDR member track points program (you don't have to be the track points champion to qualify for the SSDRS World Championships).**

### SUMMIT BRACKET FINALS MAIN EVENT CLASS CHAMPIONS

To qualify, a racer must win a main event class at any WDR Summit Bracket Finals event and have a SSDRS registration for that class on or before July 1<sup>st</sup>.

#### PROGRAM REQUIREMENTS:

- Each member track will determine their own participating classes and points structure. Tracks may submit champions in Box, No Box, Sportsman, Junior, Bike/Sled, EV.
- If a racer **qualifies at two tracks for the SSDRS World Championships** in the same class, they will have to claim one track and forfeit the other.
- A racer must have a different car for each class they compete in at the World Championships. Vehicles may not be shared.
- If a racer wins the **SSDRS track points** and a Summit Bracket Finals championship in the same class, the **SSDRS track points** will be the one recognized for purposes of the SSDRS World Championships.
- Member track **SSDRS qualifiers** can't be substituted if an eligible **qualifier** can't attend the SSDRS World Championships. **If a racer qualifies** at two different tracks in the same class, the track that the racer forfeits will have the next highest qualified racer invited.
- **WDR track owners and track managers may qualify by being the highest qualified SSDRS racer at a track other than the one they own/manage or by winning a Summit Bracket Finals main event.**
- Any racer may be disqualified from the program at the discretion of WDR or a Member Track in any instance that constitutes a round win given to one racer by another (a dive) in the sole and absolute judgement of the WDR or Member Track.



### SUMMIT WORLD CHAMPIONSHIP EVENT RULES

**GENERAL** – All classes will compete on the 1/8 mile. Down track electronic rpm limiting devices, throttle stops, non-OEM computers and GPS or track position sensing devices or sensors are prohibited. Vehicles may not be used by more than one competitor.

**BOX-** (0-9.00): Starting line enhancers, delay boxes, transmission brakes, two-steps, nitrous and playback tachometers are permitted. Only OEM factory installed computers are permitted in the vehicle. Motorcycles/sleds permitted if qualified for the event with a delay box.

**NO BOX-** (All-Run): Delay boxes prohibited and must be removed from vehicle. Starting line enhancers are prohibited. Nitrous, two steps, trans brakes and automated shifters permitted. EV permitted.

**SPORTSMAN-** (Door Cars Only, 7.40 and slower): Slicks and headers are allowed. Line locks are permitted if used only for the burnout process. OEM automated shifters are allowed. Delay boxes prohibited and must be removed from entry. Vehicles may not use starting line enhancers, transmission brakes, buttons on the steering wheel, two steps or nitrous oxide. Two steps permitted for manual transmissions only. Pneumatics, electronics, hydraulics or any other device may not affect the throttle operation in any way. Fixed, mechanical stop on carburetor linkage or throttle pedal is permitted. EV permitted.

**JUNIOR DRAGSTER:** (All-Run) Junior competitors will run in one-class regardless of license. EV permitted

**BIKE/SLED:** (All Run) Delay boxes prohibited. Two-step and nitrous permitted. **Stand alone ECU must have sportsman/no box software.**

**ELECTRIC VEHICLES:** Delay boxes prohibited. Will run as a part of the SPORTSMAN or NO BOX class depending on elapsed time. To qualify as an EV the vehicle must not be a hybrid. EV will run among themselves until one is left in competition and will then be added to the Sportsman or No Box eliminator.

### WORLD CHAMPIONSHIP EVENT RACE PROCEDURES:

- In Box, dragsters will run dragsters, door cars will run door cars and motorcycles will run motorcycles for the first two rounds when possible. If an odd number of door cars exist, the last door car in line will run the first dragster. If an odd number of motorcycles exist, the last motorcycle in line will run the first car.
- Lane choice is determined by the designated lane the racer enters. Card draw will determine uneven pairs.
- First round byes will be reserved for the Friday night Gamblers Race winners (if completed), or the best reaction time from Saturday Qualifying. Remaining rounds are reaction time in previous round. Ties will be broken by package, then the first to accomplish. Potential bye will have lane choice if paired and new bye runs will be earned every round.
- Courtesy staging will be enforced. Deep staging is permitted with "DEEP" marked on all sides of the vehicle. Deep competitor must courtesy stage by entering both the pre-stage and stage beams. The driver is responsible for deep staging in a timely manner.





## SUMMIT BRACKET FINALS

In several regions of the country where WDRA member tracks operate, there will be WDRA Summit Bracket Finals events which are open to all member tracks and their racers to participate.

Tracks will send a team of racers to compete against other teams in their region. Every WDRA Summit Bracket Finals event will award individual class champions as well as overall team champions.

A team composition will consist of racers who participate in a track's points program and must meet eligibility requirements as to the number of events attended at the facility. Team member eligibility may vary by region but will be determined by the participating tracks before each racing season begins.

Each team member that participates at a WDRA Summit Bracket Finals will have to have a WDRA membership and license that corresponds to the elapsed time structure of the class they are competing in.

WDRA Summit Bracket Finals host tracks and dates will be announced in January of each season and may change from year to year.

The format, rules, payout and schedule of each WDRA Summit Bracket Finals event will be posted on [raceWDRA.com](http://raceWDRA.com) at the beginning of the season. Racers needing more detailed information on their WDRA Summit Bracket Finals event can access this event packet on [raceWDRA.com](http://raceWDRA.com) or contact their facility management.





---

## TEEN RACING

Teens from 13 to 17 can learn the basics of drag racing and compete against other drivers of their age and skill level in a controlled and supervised environment without the need to spend any money on purpose built drag racing vehicles. An adult "co-driver" rides in the passenger seat during runs to supervise the driver. Teen Racing uses the family's daily driver as the competition vehicle so no additional expense is required.

All races are limited to 1/8 mile and elapsed times are restricted to 9.00 seconds and slower as Teen Racing is about learning the sport enjoying the experience. Junior dragster is the only other class that licensed Teen Racing drivers may compete in.

Teen Racing drivers must join WDRA and complete the license application through their local facility. Owners or a designated official will test the applicant in a driving and control skills. The applicant will make licensing runs under the supervision of the official. Once the licensing paperwork is complete and the applicant is issued a WDRA Teen Racing license, the driver will receive a WDRA Rule Book and excess medical coverage comparable to standard licenses.

### REQUIREMENTS

**DRIVER:** Birth certificate for age verification required for licensing. Teens may hold a WDRA Teen Racing license until the end of the season when they receive a full state or provincial driver's license.

**CO DRIVER:** An adult with a valid state or provincial license who is the teens legal guardian or over 25 years old must serve as a co-driver. The co-driver must be in the passenger seat of the vehicle while the teen is driving. Co-driver must drive the vehicle at all times other than when the car is at the head of staging and on the track. At that time, the driver may get in the drivers seat. After making a pass, the driver must stop on the return road and let the co-driver drive it back to the pit space.

**LICENSE:** The licensing procedure includes a basic driving test including vehicle orientation and a minimum of six license passes including the approval of a WDRA track official.

**SEAT BELTS:** Required.

**CLOTHING:** Short pants, tank tops, flannel or nylon pants are not allowed.

**VEHICLE:** Convertibles and Electric Vehicles are prohibited. Vehicle must be licensed and insured with mufflers and street tires. Purpose built race cars are not permitted. Vehicle may not have wheel tubs or have been back-halved. Aftermarket EFI systems prohibited. OEM fuel injection allowed if the year, make and model of the vehicle came with it from the factory. The use of electronics is prohibited.



THE OFFICIAL PISTON OF WDRA

IT STARTS IN THE SHOP.  
IT ENDS IN VICTORY LANE.



Engine builders are perfectionists. And so are MAHLE Motorsport engineers. Expect unmatched performance, absolute tolerances and proven durability from every piston. And if you order a POWERPAK piston kit, you also get low-drag piston rings, clips and steel pins—all designed to complement your pistons to ensure minimum friction and maximum horsepower.

## POWERPAK



Find your POWERPAK at [MAHLEmotorsport.com](http://MAHLEmotorsport.com)

# MAHLE

*Motorsport*



**BUILD SOMETHING GREAT**

| [MAHLEmotorsport.com](http://MAHLEmotorsport.com)



---

## JUNIOR DRAGSTER

Drivers aged 6 to 17 in half-scale Dragsters, Funny cars and Roadster Chassis. This youth program serves as the future of the sport of Drag Racing.

### LICENSE DESIGNATIONS

Junior Dragster license holders may compete through their 18th birthday calendar year. C J/D license holders who turn 10 during a season may complete the season. **Drivers must be at least the age listed to apply for the license levels below.** New license applications require Birth Certificates for age verification. ***ET Breaks for this category are designed for safety and therefore it is the responsibility of the driver and crew to abide.***

**D/JD (12.90):** Ages 6-7 and restricted to 12.90 seconds or slower. If a competitor runs quicker than 12.70, one warning may be issued. A second instance may result in disqualification. Competitors running 12.50 or quicker may be disqualified without warning.

**C/JD (11.90):** Ages 7-9 and restricted to 11.90 seconds or slower. If a competitor runs quicker than 11.70, one warning may be issued. A second instance may result in disqualification. Competitors running 11.50 or quicker may be disqualified without warning.

**B/JD (8.90):** Ages 10-17 and restricted to 8.90 seconds or slower. If a competitor runs quicker than 8.70, one warning may be issued. A second instance may result in disqualification. Competitors running 8.50 or quicker may be disqualified without warning.

**A/JD (7.90):** Ages 12-17 and restricted to 7.90 seconds or slower. If a competitor runs quicker than 7.70 or faster than 85 mph, one warning may be issued. A second instance may result in disqualification. Any competitor running quicker than 7.50 may be disqualified for the remainder of the event may result in immediate disqualification and license suspension at the discretion of the WDRA.

**AA/JD (7.50):** Ages 16 to 17 and restricted 7.50 or slower. Driver must have a valid state or provincial driver's license and make the required passes prior to being issued an AA/JD license. One warning will be issued if a competitor runs 90 mph or faster or an elapsed time of 7.40 or quicker. A second instance at the same event they may result in disqualification. Running 95 mph or faster or 7.30 or quicker, may result in immediate disqualification and license suspension at the discretion of the WDRA.

### REQUIREMENTS

**ARM RESTRAINTS:** Mandatory. Must be installed so that driver's hands and/or arms cannot be extended outside of roll cage or frame rails and must be combined with a driver restraint system and release with restraint mechanism. Refer to manufacturer for operational instructions.

**BALLAST:** All ballast must be secured to chassis with a minimum of one 3/8 bolt per 5 pounds. Cable clamps, hose clamps, ties wraps etc., may not be used. All ballast must be installed lower than the top of the rear tires.

**BRAKES:** Brakes must be applied and released as a direct result of driver input. Dual rear-wheel hydraulic drum or disc brakes, or WDRA accepted mechanical brakes mandatory. Hydraulic brake lines must be steel or steel

braided and high pressure brake hose must be used for vibration connections. Front brakes permitted when in conjunction with rear brakes. Live axle may have one brake when a 7-inch minimum go-kart puck-type disc brake is used. Use of drive sprocket as a brake component prohibited. Lightening or drilling of brake components prohibited. Single steel disc brake rotors must be at least 7-inch diameter with a .228-inch minimum thickness. Dual steel brake rotors must be at least 6-inch diameter with a 3/16 inch minimum thickness. Aluminum brake rotors must be 11-inch diameter with a .228-inch minimum thickness. No line line-loc allowed. Hand brake permitted, but must be directly coupled to foot brake and can-not be used separate or in replacement of foot brake unless approved by WDRA for hand control vehicles. Application and release of brakes must be a direct function of the driver; electronics, pneumatics, or any other device may in no way affect or assist brake operation. Steel brake lines are mandatory for competitors running 7.50 or 7.90.

**BODY:** Funny Cars and Roadsters are permitted providing design has been accepted prior to competition. Body must be designed to prevent any part of the driver from contacting any drivetrain components, track walls and surface. Body, including cowl may be structured from fiberglass, aluminum or carbon fiber. Body may not be drilled into chassis and must mount to tabs. Front overhang is limited and a maximum of 15" from centerline of spindle for dragsters. 25" for Funny Cars and Roadsters. Funny Car roofs must be between 35 and 40 inches high with a hatch opening at least 15 by 10 inches.

**BURNOUTS:** Vehicle may not be touched during burnout. Burnouts past the starting line are prohibited.

**CAMSHAFT:** Any camshaft permitted. Any valve spring permitted. No overhead cams permitted. Any size valves permitted.

**CARBURETOR:** Any means to pass fuel or air to the engine other than normally aspirated carburetor is prohibited. Auxiliary vacuum fuel pump permitted. Pressurized and or fuel injection systems and electric prohibited. Electric fuel pumps prohibited.

**CHAIN/BELT GUARD:** Chain and belt guards which covers the width of chain or belt and extend to the leading and following centerline and must be .060" steel, or .090" aluminum.

**CLUTCH:** Vehicles must use a dry centrifugal-type clutch with chain or belt drive. Accepted clutch face plates: Polar, Gaged Engineering, McGee Racing Cams, JR Race Car, Craw Racing, Metro Racing, Power Block (HRD), Comet, Cheetah Supply, Salisbury, Blossom Racing, M&S Machine, Haddock Ltd., MX2, and Brand X Racing Engines, Clay Smith Engineering.

**COMPUTERS:** Prohibited. See General Regulations for specific information.

**CYLINDER HEAD:** Aftermarket units permitted.

**DATA RECORDERS:** Allowed only to record engine RPM, engine temperature, exhaust temperature, and jack-shaft sensor data. The recorder may not activate any function on the car and may not sense any wheel speed, location or inertia. No recorded data may be available to driver or crew during run.

**DEFLECTOR PLATE:** A deflector plate of minimum 1/16-inch aluminum must be installed between roll cage and engine extending from lower frame rail to the top of driver's helmet. Portion between shoulder hoop and top of helmet must be minimum 7 inches wide, may be narrowed or rounded above the helmet. Two-piece plate permitted with no air gap between the two. Carbon fiber prohibited.

**DELAY BOXES:** Prohibited.

**DIAL-INS:** Competitors must display their dial-in on the race car in a way that is clearly visible to the tower and opponent. Dial In boards must be attached to the car. Dial-in cannot be changed after designated ready line.

**DRIVER:** Every effort must be made by crewmembers to implore the safety requirements for keeping all body parts inside the roll cage and all safety gear in place until the vehicles have exited the surface and stopped completely. Warnings and disqualifications may occur for any infractions.

**DRIVER RESTRAINT SYSTEM:** 5-point minimum, SFI 16.1 or 16.2, 1 3/4" wide driver restraint required. All points must release in one motion. Protective covers for all latch-lock belts required. All harness sections must be mounted as designed by manufacturer and limit travel upward and forward. Belts may not be wrapped around lower frame rails.

**ENGINE:** Only rear-mounted five horsepower based four-cycle engine allowed. No changes to deck surface area allowed. No power adders or forced induction allowed.

Accepted aftermarket engines: Flathead: Blossom Racing Engines, Huddleston Performance, JR Race Car, McGee Racing, Tecumseh, Pure Power Racing, R&S Machine. Crate Engines: JR Race Cars Thumper JD2 and Punisher JD3, Huddleston Performance Magnum OHV, Briggs and Stratton 206, **Predator Ghost 212**. All crate engines must maintain factory hologram seal. Blocks: LPW Racing Products Monster, SR 71 by Soltz Racing, M-1 Machine, TRS.

**FUEL:** Gasoline or alcohol only.

**FUEL STORAGE:** Must be securely located behind driver, below the shoulder hoop and between frame rails. All tanks must be 1-gallon or less and have a locking or screw-on cap and must be vented downward and below the tank.

**FLYWHEEL:** Unless OEM-type carburetor is used a billet aftermarket flywheel must be used. No cast Aluminum units permitted.

**GAUGES:** Engine and Cylinder head temperature gauges allowed. A tach meeting specific guidelines is permitted. See General Regulations: Data Recorders.

**GROUND CLEARANCE:** From the front of the vehicle to 12 inches behind the centerline of the front spindle, 3 inches of ground clearance is required. 2 inches required for the remainder of the vehicle. Some combinations, based on tire size and body may require more clearance for proper timing system operation during the staging process.

**HELMET:** Full face helmet with shield mandatory meeting SN, SA, M, or K-2015 or newer or FIA: 8860-2010, 8860-2015 or 8860-2018 specifications.

**IGNITION KILL SWITCH:** A mechanical ignition kill switched for both driver and crew must be used and must ground the spark plug. The crew switch must be mounted high on the center of the deflector plate on dragsters. Funny cars and Roadsters second switch may be mounted in a high central point of the rear body or on the drivers side and must be clearly labeled.

**IGNITION SYSTEM:** All ignition components must be unaltered and used in manufacturer's guidelines. Only one spark plug may be used. Magneto or battery systems allowed. MSD Ignition # 41510, 41500, and 42231 are the only accepted ignition units. Low side rpm limiter, if available, must be set to "zero." MSD 4291,8232, Master Blaster 2 and 3 are the only accepted coils.



# FUEL FACTORY™

## OUR FUELS

### LEADED

Our leaded fuels are meticulously blended to adhere to the strictest standards in the motorsport industry. Every batch is tested and certified by independent labs to ensure maximum quality and consistency.

### UNLEADED

Our unleaded fuels are formulated with super-premium components to produce maximum performance, batch after batch. Independent lab testing and certification means every drop of our fuel is second to none.

### METHANOL

Our methanol is 99.9 pure methanol, the highest purity available for combustion engines.

### ETHANOL

Our ethanol-based blends are formulated with only the purest base stocks to maintain the highest level of performance for every race fuel application.



# FUEL FACTORY™

# 412-404-3329

LICENSE: valid WDRA Competition license mandatory

# FUELFACORYUSA.COM

**NECK COLLAR/HEAD AND NECK RESTRAINT:** Neck collar mandatory unless SFI 38.1 Head and Neck Restraint system is used. The SFI 38.1 head and neck restraint device/system may be used with or without an SFI 3.3 neck collar. If the device/system is used without a neck collar, an SFI 3.3 head sock or SFI 3.3 skirted helmet mandatory. See class designations for additional information. All competitors running 7.50 must utilize SFI 38.1 head and neck restraint system.

**OIL:** No oil may be used with the intent of producing power. No oxygen bearing or power enhancing additives are permitted.

**DRIVER PROTECTIVE GEAR:** All drivers are required to wear a jacket meeting SFI Spec 3.2A-1 and 3.3 gloves as well as full-length pants, shoes and socks. The use of synthetic or flannel pants is prohibited. Competitors running 8.89 or quicker must utilize a minimum of 3.2A-1 pants in addition to what is specified above.

**RESTARTS:** Only one chance to restart must be given to restart the entry within a reasonable time at the starter's discretion. It is recommended to keep starter accessible. No push-starting of vehicles allowed.

**ROLL CAGE:** All new chassis must incorporate manufacturer's name, serial number, and date of manufacture. A minimum 5-point roll cage mandatory. Upper frame rails and hoops must be a minimum 1 1/8" diameter by .083. Diagonals must be a minimum 3/4" by .083". The maximum distance between uprights is 20 inches. 7.50 and 7.90 must incorporate construction with chromoly tubing and must include helmet bars and SFI 45.1 or 45.2 padding.

### ALL JR. DRAGSTER CHASSIS

#### Front Views

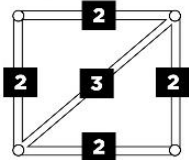

OPTION 1

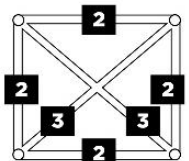

OPTION 2

#### Rear Views

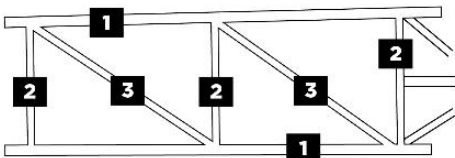
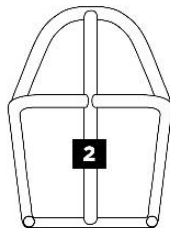
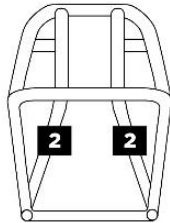

Bottom View



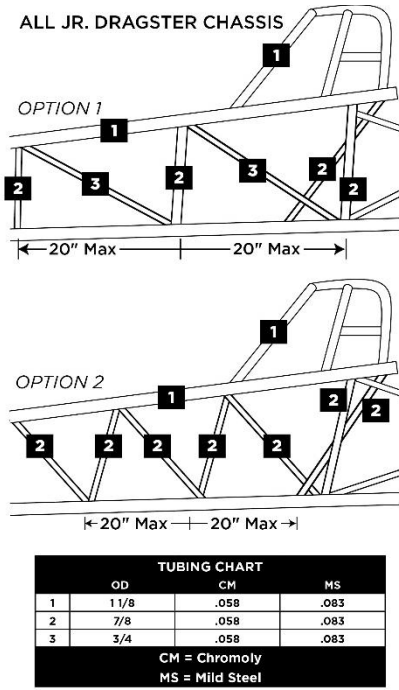

**SEAT:** Properly braced and supported seat constructed of aluminum, fiberglass or carbon fiber mandatory. Upholstery is optional.

**SHEET METAL:** Any interior panels of drivers compartment must be aluminum, steel, fiberglass, or carbon fiber. Magnesium prohibited.

**STAGING:** If a crew member touches the vehicle once it is pre-staged the entry may be disqualified. Once a car reaches the front of the staging lanes or ready-line, it must be prepared to fire and race. To be considered a race winner, a contestant's car must stage under its own power. If a vehicle loses fire, competitors will be given reasonable time to re-start as determined by the starting line officials, provided it is not pre-staged. The use of any device that permits the driver to ascertain the position of the vehicle in relation to the starting line is not allowed. At events where courtesy staging is enforced, the starter will attempt to pull the double bulbed vehicle back and allow it to re-stage. The starter has full control of all pull-back situations whether the entry is pre-staged, staged or over staged unless implicitly instructing a crew member to help. If the auto start system cycles during the pull back, the run may stand. If either car rolls deep unintentionally after auto start has been activated, the competitor accepts the deep staging and may not be pulled back.

**STAGING DEVICES:** No staging systems allowed.

**STARTER:** OEM style pull-start or handheld electric starters required. Driver may not control the starting of the vehicle.

**STEERING:** Rack & pinion steering mandatory for competitors running 7.50 or 7.90. All connections must be welded or through-bolted. Rod ends must incorporate pull-through protection via washer and must be of aircraft quality or better.



Prolube Oil is an American family owned and operated company since 1988. Our highly-concentrated products are formulated for racing, cars, trucks, boats, semis, motorcycles, lawn equipment, industrial & agriculture. Prolube specializes in creating the world's most extreme lubricants to handle almost any application.



**NOTHING COMPARES  
TO PROLUBE OIL  
TREATMENT.**

**TAIL LIGHT:** One functional tail light, which is adequately secured, mandatory. Must be visible from the rear of the vehicle by starting line officials.

**THROTTLE:** A throttle return spring which shall close throttle when released is required. Throttle control must be operated manually by driver's foot; electronics, pneumatics, hydraulics, or any other device may not affect operation. Properly mounted fixed positive stops under the pedal approved. Hand controls may be approved by WDRA for those with challenges in using foot controls.

**TIRES:** All tires must be pneumatic. Front tires must utilize manufacturers marking for maximum inflation rating. Rear tires may be no smaller than 18" diameter x 7 1/2" wide measured at widest and tallest point. Treatment of tires is prohibited in the staging lanes, water box or starting line.

**TRANSMISSION:** Gear driven transmissions are not permitted. Only belt driven torque converter assemblies allowed.

**TOWING:** Driving of vehicle through pits is not allowed under any circumstance. Tow vehicle should be operated by an adult. Vehicles can be towed by a tow strap or dolly. Any time a Jr. Drag Racing vehicle is being towed with the front tires on the ground the driver must be fully seated in the cockpit. Tow straps may not be attached to the roll cage. Tow warning flags are recommended.

**TWO WAY COMMUNICATIONS:** Any communication to or from the driver or any signals between driver/vehicle or any remote location prohibited. Use of headset or handheld radios by crewmembers in the starting-line area is prohibited. The use of any portable or handheld electronic devices are prohibited in water box or on starting line.

**VENT TUBES:** When used, all vents, breathers and catch tanks must be securely mounted and prevent fluid from depositing on the racing surface.

**WARM-UPS:** A qualified driver must be fully seated in the vehicle any time the vehicle is running.

**WHEELBASE:** Dragsters must be between 90 inches and 150 inches. Funny cars must be between 70 inches and 95 inches. Roadsters and Alteredds must be between 65 and 95 inches. Maximum 2 inch stagger allowed.

**WHEELS:** No modifications besides adding weight for balancing may be made. Front wheels must be at least 5 inches in diameter with a minimum spindle diameter of 1/2". If front spindle is not designed to use a retainer pin, a nylon locking nut must be used. Rear Wheels must be at least eight inches in diameter.

**WING:** Mandatory for AA/JD 7.50 license designation. The wing must be mounted so it is higher than the top of the roll cage.

#### **ELECTRIC POWERED JUNIOR DRAGSTER**

Electric Jr Dragsters must meet the same as any other except for the following:

A flashing yellow light must be affixed to top of roll cage indicating when electrical system is energized.

**BATTERIES:** Vehicles are permitted to use ABSORBED GLASS MAT, STARVED ELECTROLYTE, OR SEALED VENTED NICAD-style batteries for power source. Wet batteries prohibited. Batteries must be securely mounted outside of and completely sealed from the driver compartment. Batteries may not be located above top of rear tires or outside of frame in any direction. Batteries must be installed so as to withstand a force four times (vertical) and eight

times (horizontal) the weight of the battery pack, and each battery or battery pack must be secured with bolts and straps corresponding to the size and weight of the battery. Drive motor and/or high-current wiring may not be located in driver's compartment. Instrumentation wiring permitted.

**DEFLECTOR PLATE:** A deflector plate of 1/8-inch steel minimum must be installed between roll cage and battery pack extending from lower frame rail to the top of driver's helmet. Portion between lower and upper shoulder hoop must extend and attach to the body panel. Two-piece plates are permitted with no gaps. Aluminum, carbon fiber, titanium and all other materials prohibited.

**FUSING OF BATTERIES:** Battery packs must have over-current protection. Circuit breakers or fuses permitted. Such protection devices must have a rating equal to or greater than nominal pack voltage. Current rating must be lower than master disconnect, wiring, and battery pack can carry without damage. Battery sub-packs must be individually fused.

**MASTER CUTOFF:** All vehicles must incorporate a master electrical disconnect switch that must disable all electrical functions. Switch must be located on the top of the deflector plate. Switch must be clearly labeled as to position. Switch may actuate relay or contactor. All vehicles must also be equipped with a switch, attached to driver with a lanyard, capable of shutting off all power to motor. Switch may actuate relay or contactor. Solid state switch prohibited.

**MOTOR:** Vehicles are restricted to one rear-mounted electric motor in conventional position. Exposed motors must have a shield of .024-inch steel, .032-inch aluminum, or .120-inch Lexan.

**RECHARGING:** Batteries may be charged in pits or other designated areas only. Polarized connection to battery pack from charger is mandatory.

**VOLTAGE:** Maximum permitted operational voltage 144 nominal when checked at battery pack under no load using digital voltmeter. Maximum fully charged battery-pack voltage 156 volts.

**WEIGHT:** Minimum weight 225 pounds without driver. SFI 2.7 chassis required for weight greater than 400 pounds with all batteries without driver.



***FuelTech***



---

## FACTORY STREET

Factory Street provides an opportunity for factory produced hot rods to race legally and safely on a drag strip. The regulations for Factory Street vehicles rely on the manufacturers unaltered standard safety features of the vehicle to be fully functional.

Owners of newer model Corvettes, Camaros, Hellcats and Mustangs along with their foreign counterparts can do battle on the track in a safe and controlled environment instead of on the street. The WDRA encourages all member tracks to welcome these vehicles into their programs to help curtail illegal street racing.

**VEHICLE:** Limited to any 2008 or newer domestic or foreign production car or truck. Internal combustion or electric vehicle permitted. Proof of registration and valid state or provincial license plates required.

2008 -2013 model year vehicles 10.00 and slower 1/4 mile or 6.40 and slower 1/8 mile. Max speed 135 mph.

2014 and newer model year vehicles 9.00 and slower 1/4 mile or 5.65 and slower 1/8 mile. Max speed 150 mph.

**VEHICLE SAFETY EQUIPMENT:** Convertibles, T-tops and removable hard tops must meet the full specifications listed in the Elapsed Time Specific Rules for roll bar and roll cage requirements.

The vehicle must remain unaltered from the OEM and fully operational in regards to factory safety equipment including but not limited to airbags, seatbelts, stability control and ABS.

**DRIVER:** Must be at least 18. SN, SA, M or K-2015 or newer helmet required at 13.99 quarter mile and 8.59 eighth mile or quicker. At 9.99 quarter mile or 6.49 eighth mile or quicker, SFI 3.2A-5 Jacket and Pants and 3.3 neck collar are required.

**PASSENGERS:** Passengers must be 18 and are only allowed during non-elimination testing runs slower than 11.00 quarter mile or 7.00 eighth mile. Passengers meeting this criteria must use the same waiver and release process and protective equipment as the driver.

**TIRES AND WHEELS:** All tires and wheels must be DOT approved for vehicle, but do not have to be factory supplied.

**MAINTENANCE**

**INDUSTRIAL**

**SAFETY/PPE**



**1ST LAYD**



SEARCHING FOR SOMETHING, CALL US 1ST!  
WDRA TRACKS RECEIVE  
58% OFF LIST PRICE



**Sales Manager:  
Steve Schuttinga**

**Phone:  
630-417-9464**

**Email:  
1staydsteve@gmail.com**

## ELAPSED TIME SPECIFIC RULES

### *0-6.49 eighth mile; 0-9.99 quarter mile*

In addition to these guidelines, See General Tech and Race Regulations.

**AXLES:** Aftermarket axle shafts and retention devices required.

**BRAKES:** 4-wheel brakes are mandatory on all full-bodies vehicles. Vehicles running 5.49 or quicker eighth mile or 8.49 or quicker quarter mile must use a dual-reservoir master cylinder.

**DATA RECORDERS:** Allowed. See General Regulations.

**DRIVELINE:** Driveshaft loop (1 minimum) required.

**DRIVER RESTRAINT SYSTEM:** SFI 16.1 or 16.5 within manufacturers expiration date mandatory.

**FIRE SYSTEM:** All closed body cars, **front engine dragsters and open bodied supercharged or turbocharged vehicles on gas or methanol** 4.49 or quicker 1/8 or 7.49 or quicker 1/4 require a fire system. One nozzle located on the firewall in the drivers compartment and one on engine. A secured fire extinguisher is mandatory on all other closed body entries. All systems must have clearly identifiable release pins.

**FLEXPLATE:** SFI 29.1 required.

**FLEXPLATE SHIELD:** SFI 30.1 required.

**FLOOR:** Floor on all cars 5.49 or quicker in the 1/8 mile or 8.49 or quicker 1/4 mile. Floor must be steel on the driver's side, thickness .024. All other places may be .032 aluminum.

**FUEL SYSTEM:** Any batteries, fuel lines, fuel pumps or tanks located inside trunk must be isolated from the driver's compartment and vented outside of body. Fuel lines must be routed outside driver's compartment. Tanks must be mounted lower than the top of rear tires.

**HARMONIC BALANCER:** SFI 18.1 required.

**HELMET:** SA, SN, M or K-2015 or newer mandatory. Open bodied entries must utilize a full-face helmet.

**LICENSE:** Mandatory. See General regulations.

**MASTER CUTOFF:** Mandatory. See General Regulations.

**PARACHUTE:** Required at 125 mph 1/8 mile or 150 mph 1/4 mile.

**DRIVER PROTECTIVE GEAR:** 3.2 A-5 jacket is required. 3.2A-5 Jacket and Pants and 3.3 neck collar are required on vehicles running 9.00 or quicker quarter mile or 6.00 or quicker eighth mile. 3.3-1 gloves are required on vehicles running 8.49 or quicker quarter mile or 5.49 eighth mile. 3.3 arm restraints and 3.3-1 gloves are mandatory on all on open bodied vehicles.

**ROLL CAGE:** Roll cage required. Roll bar is permitted in place of roll cage for full bodied vehicles with an unaltered floor and firewall running 6.40 or slower in the eighth mile. All entries running 6.00 or quicker eighth mile or 9.00 or quicker quarter mile must have a current chassis certification. See SFI specifications and general regulations for detailed information.

**TAIL LIGHT:** Functional tail light mandatory. It must be visible from the rear of the vehicle.

**TRANSMISSION SHIELD:** SFI 4.1 required.

## ***6.50-7.49 eighth mile; 10-11.49 quarter mile***

**In addition to these guidelines, see General Tech and Race Regulations.**

**AXLES:** Aftermarket axle shafts and retention devices required on vehicles at 6.99 and quicker eighth mile or 10.99 and quicker quarter mile.

**BRAKES:** Two rear-wheel hydraulic brakes mandatory. Four-wheel brakes mandatory on full bodied vehicles. ~~Entries with only two-wheel brakes must be equipped with a functional parachute.~~

**CHASSIS:** See General Race Regulations.

**DATA RECORDERS:** Allowed. See General Technical Regulations.

**DRIVELINE:** Driveshaft loop (1 minimum) required.

**DRIVER RESTRAINT SYSTEM:** SFI 16.1 or 16.5 required.

**FIRE EXTINGUISHERS:** A secured fire extinguisher is mandatory on all closed body entries.

**FLYWHEEL SHIELD:** SFI 6.1 shield required if 135mph or faster.

**FLEX PLATE:** SFI 29.1 required if 135 mph or faster.

**FUEL SYSTEM:** Any batteries, fuel lines, fuel pumps or tanks located inside trunk must be isolated from the driver's compartment and vented outside of body. Fuel lines must be routed outside driver's compartment. Tanks must be mounted lower than the top of rear tires. Fuel cell optional.

**HARMONIC BALANCER:** 6.99 and quicker eighth mile or 10.99 and quicker quarter mile require a balancer meeting SFI 18.1 spec.

**HELMET:** SA, SN, M or K-2015 or newer required. Open bodied entries must utilize a full-face helmet.

**MASTER CUTOFF:** See General Regulations.

**DRIVER PROTECTIVE GEAR:** Open bodied vehicles require SFI 3.2A-5 jacket, arm restraints and SFI 3.3-1 gloves. 3.2A-1 jacket required on full bodied vehicles.

**ROLL CAGE/ROLL BAR:** A roll cage is required if the vehicles floor or firewall have been altered, or if vehicle exceeds 135 mph. Roll bar required:

- All cars 6.50 to 7.35 eighth mile or 10.00 to 11.49 quarter mile.

- Convertibles running 7.00 to 8.25 eighth mile or 11.00 to 13.49 quarter mile (t-tops included).

- Dune-buggy-type or open top vehicles running 7.50 and slower eighth mile and 12.00 seconds and slower quarter mile.

**TAIL LIGHT:** Working tail light required. Must be visible from the rear of the vehicle.

**TRANSMISSION SHIELD:** Automatic transmission equipped entries running 10.99 and quicker quarter mile or 6.99 and quicker eighth mile requires SFI 4.1 spec shield.

**WHEELBASE:** 85" minimum unless OEM wheelbase was less. Minimum of 125 inches on dragsters. Left to right wheelbase variation of 1" maximum.



## ***7.50-9.00 eighth mile; 11.50-13.49 quarter mile***

**In addition to these guidelines, see General Tech and Race Regulations.**

**BODY:** Required.

**BRAKES:** 2 rear wheel brakes minimum are required.

**DRIVELINE:** Driveshaft loop (1 minimum) required when using racing slicks.

**DRIVER:** Driver's seat may be moved a maximum of 10" rearward but must remain in factory location.

**FRONT OVER HANG:** Nothing may be added to the front of the vehicle which will add to the overall length of the body.

**FUEL SYSTEM:** Any batteries, fuel lines, fuel pumps or tanks located inside trunk must be isolated from the driver's compartment and vented outside of body. Fuel lines must be routed outside driver's compartment.

**HELMET:** SN, SA, M or K-2015 or newer required.

**HOOD:** See General Technical Regulations.

**MASTER CUTOFF:** See General Technical Regulations.

**ROLL BAR/ROLL CAGE:** A roll cage is mandatory on any entry that exceeds 135 mph. A 6-point roll bar is mandatory on all convertibles running 8.25 or quicker eighth mile and 11.00 to 13.49 quarter mile.

**TAIL LIGHT:** Working tail light required. Must be visible from the rear of the vehicle.

**TRANSMISSION SHIELD:** Modified automatic transmissions or converters are recommended to utilize SFI 4.1 transmission blanket or shield.

**WHEELBASE:** Must be at least 85" unless OEM was less and vehicle has original engine configuration and placement. Left to right wheelbase variation of 1" maximum.

**WINDSHIELD/WINDOWS:** Replacement windows must be 1/8" minimum Lexan. All windows must be clear without excessive tinting.



# JONES

TRANSMISSION COOLING SYSTEM

**COOL YOUR  
TRANS FLUID  
BETWEEN  
ROUNDS.**



**-GARY  
STINNETT**



## 724-413-4383

# \$599

Applicable for bracket and turbo cars, any car with an automatic transmission with a convert and Pro Mods with a converter. This kit has been tested over a four year period on a 7 second, 180 mph dragster and is already used by many racers.

It is very universal and can be mounted in any position. The pictures show a dragster application and the kit picture shows the contents. All you need to do is mount the pump, wire the relay and switch, make a couple of lines and that's it! Very Simple! We do highly recommend a separate fan for your transmission cooler.

The kit comes complete with detailed instructions, a photograph for quick reference and a direct number for Bob Jones (724) 344-1156 for any questions you might have.



*Universal Kit*



*Dragster Kit*  
*Call for Pricing*

*Do you monitor your transmission fluid temperature? You Should!*  
Transmission temperatures affect your complete run and in later rounds, it gets worse.

# COMPONENT PARTS AVAILABLE FOR DRAGSTER INSTALLATION

## **9.00 & slower 1/8 mile; 13.50 & slower 1/4 mile**

**In addition to these guidelines, see General Tech and Race Regulations.**

**BODY:** Dragsters, altered or roadsters prohibited.

**BRAKES:** Four-wheel required.

**DRIVELINE:** Drive shaft loop required on any vehicle using racing slicks. See General Regulations.

**DRIVER:** Stock location required.

**FIREWALL:** OEM required. Clearance and repair must be done with OEM style and thickness material.

**FLOOR:** Full floor required.

**FUEL SYSTEM:** One stock location fuel tank allowed. Fuel cells recommended. Top of fuel tank not to be mounted higher than the top of rear tires.

**HELMET:** 8.59 eighth mile and 13.99 quarter mile or quicker require helmet meeting SN, SA, M or K-2015 or newer. 8.60 eighth mile and 14.00 quarter mile & slower, recommended helmet meeting the same criteria **or required if roll bar is installed.**

**HOOD:** See General Regulations

**MASTER CUTOFF:** See General Regulations.

**ROLL BAR:** See General Regulations.

**TAIL LIGHT:** Working tail light required. Must be visible from the rear of the vehicle.

**TRANSMISSION:** Any OEM type transmission with neutral safety switch required.

**WHEELBASE:** Minimum 90" unless OEM was less and vehicle has original engine. Left to right wheelbase variation of 1" maximum.

**WHEELS:** Minimum 13" diameter automotive-type wheels suitable for street use. Automotive wire or motorcycle wheels prohibited.

## **ELECTRIC VEHICLE**

*In an effort to form a universal approach to EV racing, the WDRA has adopted the National Electric Drag Racing Association rules with their approval.*

**BATTERIES:** Must be securely mounted. Batteries must be isolated from the driver's compartment. Battery packs physically inside the driver's compartment must be fully enclosed in boxes. Batteries must be installed so as to withstand a force 4 times (vertical) and 8 times (horizontal) the weight of the battery pack and each battery or battery pack must be secured with bolts and straps commensurate with the size and weight of the battery.

Battery may not be located above the top of the rear or drive tires in open wheeled cars, nor outside the body lines in bodied car, except OEM production line electric powered vehicles. All open bodied vehicles must use absorbed glass mat or starved electrolyte batteries for power source.

**FUSING BATTERIES:** All battery packs must have over current protection. Circuit breaker(s) or fuse(s) permitted. Such protection devices must have a DC voltage rating equal or greater to the nominal pack voltage. Current rating must be lower than a short circuit current that pack can produce without damage. Battery sub-packs must be individually fused.

**RECHARGING:** Batteries may be recharged in the pits or other designated areas only. All vehicles must be connected to AC power supply (earth) ground when charging. All battery chargers must be equipped with an output fuse rated for 600 volts and a current capacity at least 125% of the maximum charger DC output.

**IGNITION:** All vehicles must have a visible indication of a 'live' car, except OEM. A RED triangle must be clearly visible the power system is turned on. This may be a light or a mechanical indicator. Traction battery pack must be physically disconnected when switch is in the off position.

**MASTER CUTOFF:** All vehicles except OEM must incorporate a master electrical disconnect switch that must disable all electrical functions. Switch must disconnect traction motor battery pack section of circuit, and if switch is push-pull design, push must be 'off' function. Switch must be located at rear of vehicle.

**ELECTRICAL:** All traction motor wiring must be isolated from the chassis and may not be located inside the driver's compartment. Instrumentation wiring permitted.

**WIRING:** All high-voltage wiring must be located and secured to prevent contact by driver and/or spectators. Any wiring over 24 volts must be completely covered.

**MOTOR:** Electric Motor(s) only permitted. Maximum height of electric motor output shaft centerline 36-inches on OEM trucks; all others 24-inches. Exposed-motor electric-powered vehicles with open frame, vented, or brush replacement window motors must install a motor shield, minimum 0.024-inch steel or 0.032-inch aluminum, or 0.120-inch Lexan.

**FUEL SYSTEM:** All conversion vehicles must remove fuel tanks and fuel system, including vapor storage equipment, from vehicle.

**CLUTCH, FLYWHEEL, FLYWHEEL SHIELD:** Flywheel and clutch meeting SFI Spec 1.1 or 1.2 (2-disk maximum) mandatory on any car running 11.99 (7.49) or quicker. Flywheel shield meeting SFI Spec 6.1, 6.2, or 6.3 mandatory on all cars running 11.99 (7.49) or quicker. A motor plate, minimum .125-inch steel or 1-2-inch aluminum, may be used to adapt the motor to conventional transmission.

**REAREND:** Chain drive vehicles must be equipped with a chain guard constructed with minimum 0.125-inch steel or 0.250-inch aluminum, covering width and top run of chain to centerline of sprockets.

**DEFLECTOR PLATE (OPEN BODIED):** Each vehicle must have protection for driver from traction motor overload. Must protect driver from motor plasma, flying commutator bars, molten copper, bursting batteries, and spraying electrolyte.

**WHEELBASE:** Minimum 90-inches, unless the car has original motor or is a conversion electric powered vehicle with motor in original (internal combustion) position.

**ELECTRIC MOTORCYCLE:** Requirements and specifications for electric powered motorcycles are the same as Motorcycle and Electric Powered Vehicles with the following exceptions:

**MOTOR:** Electric motor(s) only permitted.

**BATTERIES:** Wet, (free liquid) battery prohibited.

**MASTER CUTOFF:** All electric motorcycles must be equipped with a switch, attached to the rider with a lanyard, capable of shutting off all power to electric traction motor.

# **BORGESON**

***Steering You Forward***

***Save some weight and get  
down the track quicker with  
BORGESON power to manual  
conversion kits***

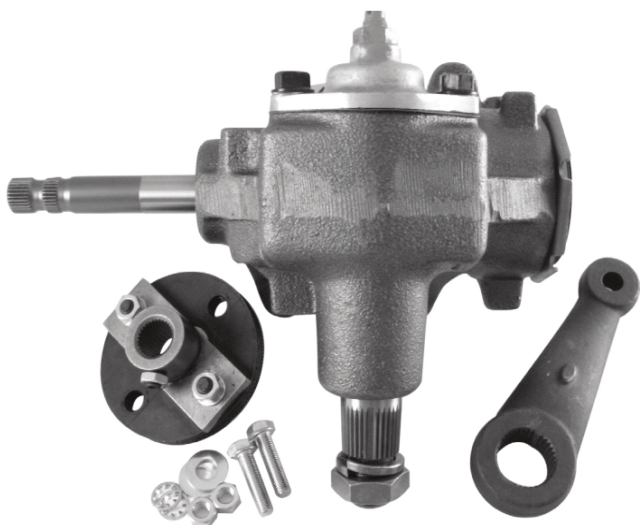

## **Power to manual conversion kits**

- 23 lbs lighter than power steering.
- Includes rag joint & pitman arm.
- No need for a HP robbing pump.
- 1964-1972 GM A-Body Cars.
- 1978-1988 GM G-Body Cars.
- 1970-1992 GM F-Body Cars.
- And many other GM applications.
- Quick ratio units available.

***www.borgeson.com***

## MOTORCYCLE

**BRAKES:** Front and **rear brakes** required.

**DRIVELINE:** Clutch cover required. Chain guard covering the width of chain and extends to the top centerline of the rear sprocket required.

**HELMET:** 2015 or newer closed-face SN, SA, M or K helmet required. 6.50 or slower in the eighth mile or 10.00 and slower quarter mile may use ECE 22.05 model.

**IGNITION KILL SWITCH:** 10.99 1/4 or 6.99 1/8 or quicker must be equipped with a positive ignition cutoff switch attached to the rider with a lanyard. OEM cutoff permitted in place of lanyard. Switch must be on low-voltage side of the ignition circuit.

**LICENSE:** 6.49 or quicker eighth mile, or 9.99 or quicker quarter mile must have a current Competition License.

**NITROUS OXIDE:** Must be installed by manufacturers guidelines and include all safety components.

**DRIVER PROTECTIVE GEAR:** Full-zip leathers or SFI Spec 40.1/1 or 40.1/2 recommended. Must use footwear that covers the ankle, leather gloves and a leather or Kevlar jacket. 10.99 quarter mile or 6.99 eighth mile or quicker must also have leather or Kevlar pants. Nylon or textile clothing not permitted.

**SUSPENSION:** Rigid front suspension is not permitted.

**SWITCHES:** Factory tip-over switch or engine kill switch attached to rider is required on 0 to 10.99 quarter mile and 0 to 6.99 eighth mile.

**TAIL LIGHT:** Working tail light mandatory. Must be visible from the rear of the vehicle.

**THROTTLE:** Working throttle return required.

## SNOWMOBILE

**AIR DAMS:** May not extend beyond the confines of the body and must have 3 inches of ground clearance minimum. Fins or other forward attachments prohibited.

**BRAKES:** OEM type required. Aftermarket additional brakes must be installed on drive axle.

**DRIVE TRAIN CLUTCH:** Clutch must be specifically designed and manufactured for snowmobile use. Chains, pulleys, belts, and exposed moving parts must be isolated from the driver and other competitors by securely mounted shields. OEM clutch covers/guards are permitted only when the unmodified OEM engine or replacement is used. Modified engines require a clutch cover/guard that provides 360 degree elliptical coverage in the direction of clutch/belt travel. The clutch cover/guard must be minimum .090-inch aluminum or .060-inch steel and be covered with securely fastened, 6-inch-wide, industrial-type belt or minimum .125-inch aluminum or minimum .090-inch steel. Bolted removable side panels may have clutch cover/guard bolted to side panels. Clutch cover/guard must be separate from the cowl.

**DRIVE TRACK:** Drive track must be smooth with no paddles or studs. External slide rail lubrication systems prohibited. Sleds running 9.99 or quicker require the use of an aftermarket track designed for concrete and asphalt surfaces.

**ENGINE:** Any engine designed for automobile, motorcycle, aircraft or marine use prohibited. Must be specifically designed and manufactured for production snowmobile use. Modifications permitted. Displacement limited to 1,000 cc's.

**EXHAUST:** Must not protrude more than 3-inches beyond the chassis or hood.

**FUEL:** Gasoline only. Race gas permitted.

**FUEL TANK:** Fuel cell permitted. Factory oil injection tank used for fuel prohibited.

**HELMET:** 2015 or newer closed-face SN, SA, M or K helmet required. 6.50 or slower in the eighth mile or 10.00 and slower quarter mile may use ECE 22.05 model.

**IGNITION KILL SWITCH:** 10.99 ¼ or 6.99 1/8 or quicker must be equipped with a positive ignition cutoff switch attached to the rider with a lanyard. OEM cutoff permitted in place of lanyard. Switch must be on low-voltage side of the ignition circuit.

**DRIVER PROTECTIVE GEAR:** Full-zip leathers or SFI Spec 40.1/1 or 40.1/2 recommended. Footwear that covers the ankle, leather gloves and a leather or Kevlar jacket required. 10.99 quarter mile or 6.99 eighth mile must also have leather or Kevlar pants. Nylon or textile clothing not permitted.

**SKIS AND WHEELS:** Must be rubber specifically designed for snowmobile use on a racing surface. Must be installed with the intent to keep skis from coming in contact with track surface. Skis must be aluminum or steel. Minimum distance between each ski is 9.5 inches.

**SNOWFLAP:** If vehicle is equipped with a rear snow flap it must be fastened to the tunnel so that it can not be inverted into the tunnel.

**SUSPENSION:** 1" minimum of travel in the track suspension required. Externally activated suspension systems prohibited. Minimum of 4 bogie wheels must be utilized on each side of the rear suspension to stop the slide rails from coming into contact with track surface.

**TAIL LIGHT:** Working tail light mandatory. Must be visible from the rear of the vehicle.

## **ATV/UTV**

Eighth mile competition only. Restricted to 4-wheel ATV's or UTV's with **single driver only and no passengers**. Competition with full size vehicles prohibited.

**BRAKES:** Front and rear required.

**DRIVELINE:** Clutch cover required. Chain or belt guard which covers the width of chain or belt and extends to the top centerline of the rear sprocket required.

**HELMET:** 2015 or newer closed-face SN, SA, M or K helmet required. 6.50 or slower in the eighth mile may use ECE 22.05 model.

**IGNITION:** Engine kill switch attached to rider mandatory.

**LICENSE:** Valid State driver's license required. WDRA competition license required at 6.49 or quicker in the eighth mile.

**NITROUS OXIDE:** Prohibited.

**DRIVER PROTECTIVE GEAR:** Full-zip leathers or SFI Spec 40.1/1 or 40.1/2 recommended. Must use footwear that covers the ankle, leather gloves and a leather or Kevlar jacket. 6.99 or quicker eighth mile must also have leather or Kevlar pants. Nylon or textile clothing not permitted.

**THROTTLE:** Functional throttle return required.

**TIRES:** Must use roadway type tires. Dirt or mud tires prohibited.

AMERICAN RACE CARS

# Champions Built Here



We strive for excellence in customer service. Our goal is to keep the sport of drag racing alive, therefore whatever we can do from universal parts, car repairs, brand new builds, apparel & more!

419-836-5070

Follow us on social media:

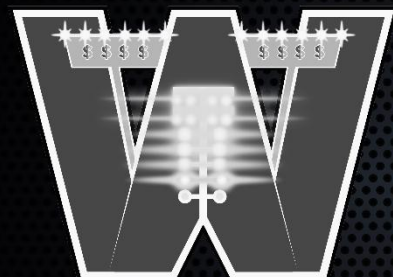

## DRAG RACING'S SPORTSBOOK



OFFICIAL FAN  
ENGAGEMENT  
PARTNER



### WINLIGHT BETS



## **SPECIAL VEHICLES**

### **SEMI-TRUCK GUIDELINES**

Drivers must hold a current CDL. DOT Vehicle inspection required. OEM driver safety features required. See General Regulations for additional requirements based upon Elapsed Time specific rules.

### **PIT VEHICLE COMPETITION**

Limited to 1/8 mile. Drivers must be at least 16 years old. A minor release form must be completed by legal guardian prior to competition. SN, SA, M or K-2015 or newer helmet required for all 2-wheel vehicles or any 4-wheel vehicles exceeding 20-mph.

### **MATCH RACE EXHIBITION VEHICLES**

A current Competition license required. Chassis inspection required on 6.00 and quicker eighth mile or 9.00 and quicker quarter mile vehicles. Contact the WDRA technical department for specific requirements for exhibition vehicles. All vehicle designs and driver credentials must be accepted prior to participation at any WDRA sanctioned facility.

### **ROCKETS**

Really really prohibited.

### **RIDE ALONG DRAGSTER**

Passenger must be 18 years or older. When a passenger is present the run is limited to a solo run exhibition only. Restricted to eighth mile runs of 5.00 seconds or slower and 135mph or slower. Driver and passenger must wear SN-2015 or newer helmet, SFI 3.3 neck collar, SFI 3.3/5 gloves, SFI 3.3 arm restraints and SFI 3.2A/5 driver's suit. Primary driver must have a current WDRA license and vehicle must meet all safety requirements for its elapsed time.

### **WHEELSTANDER**

Driver must have a current competition license and the vehicle must meet all safety requirements for the elapsed time it runs. See WDRA supplemental rulebook on [racewdra.com](http://racewdra.com) for additional information.

### **NITRO POWERED VEHICLES**

Valid Competition license and chassis inspection required for Nitro Funny Cars, Altereds, Dragsters and Bikes. See WDRA supplemental rulebook on [racewdra.com](http://racewdra.com) for additional information.

### **JET VEHICLE**

**GENERAL REQUIREMENTS:** Competition license and chassis inspection required. Driver must be at least 18 years old. Contact WDRA technical department for specifications on minimum weight, chassis, and suspension requirements.

**AFTERBURNER-TAILPIPE:** A dump valve on afterburner manifold is required and must be activated by parachute lever. All seams in tailpipe must be at the bottom, centrally located away from tires.

**AIR INTAKE:** Any intake air must pass through a protective screen to prevent debris from entering.

**BRAKES:** Required on all wheels. Disc brakes recommended where applicable.

**CONTROL CABLES:** Afterburner and Fuel shutoff control cables must be 3/8 or electronically actuated. Secondary systems required.

**DRIVER RESTRAINT SYSTEM:** SFI 16.1 or 16.5 or better required.

**FILTER:** A filter is mandatory on inlet for hot streak.

**FIRE EXTINGUISHER SYSTEM:** Funny cars and oversize vehicles required to have 10lb. Enclosed cockpit dragsters 5lbs.

**PARACHUTES:** Dual parachutes are required. Parachute tubes when used may be steel, aluminum, or carbon fiber. All unpacked shroud lines must be covered by fire retardant and heat resistant material. Primary parachute lever must also function as primary fuel shutoff and complete secondary system is required with fuel bypass capabilities. All parachutes, lines and attachments must remain shielded from tailpipe heat and flame and must have a 1-inch mounting bolt minimum.

**DRIVER PROTECTIVE GEAR:** SA -2015 or newer or SFI 31.2 helmet required. SFI 38.1 head and neck restraint required. Funny Cars: SFI 3.2A/20 and Dragsters: 3.2A/15 or better. Gloves and boots SFI 3.3/5 minimum and SFI 3.3 Neck Collar.

**ROLL CAGE:** Mandatory meeting SFI specs 2.3, 2.2, or 10.1.

**SPEED LIMITS:** Dragsters and Funny Cars 310 mph. Motorcycles 210 mph. Special Vehicles 235 mph. Violations may result in fines and or suspension.

# OUTLAW Trailers

## RACE TRAILERS

FROM MILD TO WILD - WE BUILD THEM ALL!

**FAMILY OWNED  
BY INDUSTRY  
PROFESSIONALS**

- **SOLD BY RACERS FOR RACERS**
- **CUSTOM Enclosed Race Trailers**
- **Basic Enclosed Race Trailers**
- **Stacker Enclosed Race Trailers**
- **TOP QUALITY**
- **PRICE COMPETITIVE**
- **FAST LEAD TIMES**
- **3 YEAR WARRANTY**
- **ON-SITE SERVICE**
- **EASY COMMUNICATION**



**(865) 657-9077**

1383 EAST LEE HWY, LOUDON, TN 37774

**WWW.OUTLAWTRAILERS.NET**

All our current stock is listed on our website  
with pictures, specs & pricing.

## GENERAL TECHNICAL REGULATIONS

These rules and regulations are intended as a guide for the conduct of the sport and are in no way a guarantee against injury or death to participants or spectators. These rules express no implied warranty or safety in any way. Vehicles must pass technical inspection before making a run. Unless authorized by a WDRA race official, anything not itemized as being allowed is not permitted. WDRA and facility race officials and inspectors hold the right to inspect any vehicle at any time and disqualify any competitor, vehicle or participant from any event at any time. Any violation of the rules or any situation deemed unsafe by such officials may be grounds for disqualification.

**ALIGNMENT:** Vehicles must have proper wheel alignment to produce safe and controlled handling characteristics.

**AUTHORITY:** Event officials and WDRA have the authority to disqualify or suspend any participant or vehicle from an event for violation of any of the decisions, rules, or regulations of the Event or WDRA rules or decisions. Any unsafe condition, deemed by officials may be used for grounds until remedied.

**BALLAST:** No liquid or loose ballast. Dragsters limited to a maximum of 200 lbs. of ballast. Weight must not be attached to the front axle. Weight must be securely fastened to the frame by at least two 1/2" diameter steel bolts. Must be attached as a part of the car's structure and may not extend behind the rear of the body or above the height of the rear tires.

**BATTERIES:** Two starting batteries maximum are permitted not to exceed 150 lbs. combined weight. Relocated batteries must be secured with a minimum of two 3/8" diameter bolts or rods. When relocated to the rear of vehicle, the passenger compartment must be protected by a "firewall" consisting of a minimum of .024" steel or .032" aluminum. Wet-cell batteries are not permitted in the driver or passenger compartments. When relocated, a switch must shut off the positive side of all electrical functions.

**BLOW SHIELD:** Rear-engine dragsters require a deflector plate style blow shield between all engine components and cage. Must cover torso, shoulders and helmet from any debris from the rear.

**BODIES:** Vehicles must be equipped with a body surrounding the driver and extend to the firewall. Must be made of flame proof material and be constructed to prevent the driver's arms, legs or body from coming in contact with drivetrain, exhaust, or track surface and walls. OEM bodies which have been gutted must have all sharp edges removed from the inside of the body. Reproduction body panels must be mounted securely.

**BRAKES:** A minimum of two hydraulic brakes are required on all open bodied cars. All full-bodied cars must have 4-wheel brakes. Secondary brake systems permitted. Master cylinder must be above frame. Aftermarket brake systems must use a positive stop to prevent the pedal from over-extending. All line-lock systems must be normally open and self-return. Automatic braking prohibited unless OEM equipped and in OEM function.

**BRAKE LINES:** All lines must be routed outside of frame rails or protected by 1/8 inch steel when passing bellhousing area. No copper brake lines allowed.

**BREATHERS:** 5.49 or quicker eighth mile or 7.99 or quicker quarter mile require positive locking crank case breathers. Must vent into sealed portion of frame or chassis or accepted overflow container.

**CAMERAS/VIDEO:** No video monitors or video display screens permitted in or on any vehicle. Cameras/video may not be used in any way to determine track position in real time.

**CHASSIS CERTIFICATION:** Mandatory on all entries running 6.00 or quicker eighth mile or 9.00 or quicker quarter mile or vehicles that exceed 150 MPH.

**CLUTCH:** Manual transmissions must use a foot-operated clutch. All pedals must incorporate a positive stop to prevent clutch from going over center. Clutches must meet SFI Spec per appropriate use. No electronics, pneumatics, or any other device may affect clutch operation. OEM style cast iron flywheels not accepted.

**COMMUNICATION:** One or two-way communication permitted in ET bracket classes except Junior Dragster. Radios must be securely mounted in the vehicle and may not have any telemetry functions.

**COMPUTER:** OEM type installed on Stock vehicles by original manufacturers for proper operation of its functions are acceptable. A computer is considered anything electrical, mechanical, pneumatic, etc. that activates or controls any function of the vehicle based on sensing or measuring any data related to vehicle performance.

**COOLING SYSTEM:** Glycol based liquids and antifreeze prohibited in system.

**DATA RECORDERS:** Data recorders may only be used to record functions of a vehicle so long as they do not activate any function on the vehicle. For non-OEM data recorder applications, the transmission or display of any vehicle performance data processed by the data recorder, to the driver or any remote location is prohibited. Data may only be reviewed after the run. All non-OEM data recording devices must be activated by a separate switch from all other vehicle functions. No functions of the vehicle may be affected by the function of the starting system of the facility nor sense the operation of such. All lines corresponding to sensing flow or pressure of fuel or oil must be steel braided. No sensors allowed to measure cylinder pressure. No device other than OEM may be used to determine track position nor relation of one vehicle to another.

**DELAY BOX OR DEVICE:** A delay box or delay device is any device used for the express purpose of creating a delay between the release of transmission brake line-lock, or two-step button, or release of foot or hand brake, or release of clutch, or release of any other device and the resultant action of the vehicle. In instances where delay is not allowed, all switches, buttons, wiring and associated hardware must be designed for normal automotive use. Delay devices and all associated hardware must be used unaltered and be consistent with the manufacturers installation instructions. Wiring of delay device, throttle stop, ignition system, shifter and fuel injection must be labeled and traceable. Wire to the transmission brake, line lock or solenoid is the only wire that may run to the delay device but may splice to activate a two-step or launch control.

**DRIVE LINE:** If there is no usable crossmember, all vehicles using open drive shafts and required by rules must use a retainer loop made of ¼ inch or thicker steel, 2 inches wide located within 6 inches of the front universal joint in order to contain the drive shaft in event of universal joint failure. Any part of the driveline near any part of the driver's body must be enclosed in 1/8 or thicker steel. Vehicles which require the driver to sit over, or aft of the rear axle must use a protective shield of .120 inch steel plate. Enclosed drive lines using universal joints require the shield be mounted to the center section and bellhousing or adjoining frame. Couplers are recommended in place of U-joints. For units with straight couplers, the minimum requirement is .063" aluminum.

**DRIVER RESTRAINT SYSTEM:** All systems must release all belts with one motion. Vehicles that mandate a roll bar or roll cage must utilize an SFI 16.1 or 16.5 driver restraint system. In those not required, a quick-release type restraint system must be used. In OEM seat vehicles the crotch strap may be placed in front of seat instead of through seat. All hardware must be fastened to frame or reinforced mounting point beyond floor pans. Wrap-around belt styles may not use the lower frame rails or any cross member that may damage the belt in the event of contact with racing surface or retaining walls. If used for installation, flat steel plates must be a minimum of 1/4" thickness and have rounded edges to prevent cutting seat belts. In all

# **CHAMP PANS** Quality Racing Products by JR Manufacturing

**FAMILY OWNED & OPERATED  
SINCE 1982!**



- **OVER 1,000 PRODUCTS**
- **LARGE IN-STOCK INVENTORY**
- **OFTEN SAME DAY SHIPPING**

**ALL OIL PANS ARE CHECKED FOR  
PROPER FITMENT ON ENGINE BLOCKS  
BEFORE SHIPPING!**

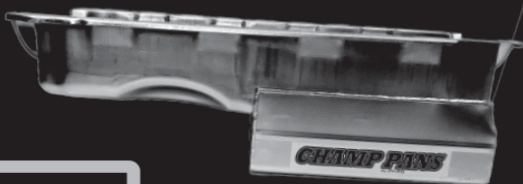

**CHAMP PANS  
WEBSITE**

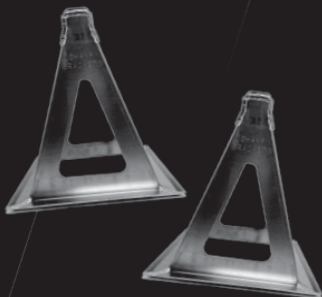

**ORDER BY PHONE- 715-834-7748  
OR EMAIL- JRMFG@CHAMPPANS.COM**

cars without appropriate structure, a cross member measuring 2 inch x .083 inch wall thickness tubing may be used. When required, arm restraints must be installed and used in a way to prevent the drivers limb from exiting the frame rails or come in contact with anything outside the confines of the drivers compartment during a collision and must be released when removing the belts as one motion. Latch-lever systems incorporating arm restraints must have a protective cover to decrease the likelihood of accidental release. In vehicles requiring updating, SFI rated systems must be updated or replaced at applicable intervals. In those not required, belts may be inspected for wear or the use of OEM style torso crossing belts may be used.

**ENGINE CONTAINMENT SYSTEM:** Lower engine containment is necessary and required for all forced induction vehicles at 4.99 or quicker eighth mile or 7.99 or quicker quarter mile. Belly pan may be used instead of diaper only if it extends to each frame rail, beyond the engine and all related components, contains an oil absorbing mat and is a minimum of 2 inches tall at its perimeter.

**EXHAUST:** Collectors must direct the exhaust gasses away from the car. Slip on header collectors that use springs or less than 4 welded tabs on collector and primaries must use a tethering system. Welded collectors required to be welded to each primary.

**FIRE SYSTEM:** Must be mounted as per manufacturers specifications. Primary function of system should be to protect the driver. Further nozzles can be used in engine bay. Upon activation the contents of the bottle(s) must be totally discharged. All bottles must be identified with a gross weight and must be DOT rated if mounted on driver side of any firewall.

Steel or aluminum distribution tubing mandatory and the use of nozzles or tubing other than that recommended by the manufacturer is not permitted. Remote cables must be installed within easy reach of the driver. Safety pins should be flagged and removed prior to burnout. As fire is a constant threat, it is requested that each crew vehicle and tow vehicle have a serviceable fire extinguisher at the ready if needed.

**FIREWALL:** Must be flame proof and fuel proof even if constructed from fiberglass or carbon fiber and must span to both body sides from the top of the engine bay to the floor and be designed to create a sealed bulkhead between the engine and driver. Any non-used OEM holes or subsequent openings may be sealed with .024 inch steel or .032 inch aluminum.

**FLASH SHIELD:** If there is no hood, carbureted vehicles must be equipped with a metal flash shield to prevent gas from being siphoned into the air stream. If no flash shield is present, open carburetors must use some type of cover. Injector stacks may be in free air.

**FLOORS:** All vehicles without floors must have floor pans made of .024" steel or .032" aluminum and be present throughout the driver's compartment to the rear of the driver's seat. Vehicles equipped with belly pans made of fiberglass or other breakable material must have metal floors or tinwork.

**FLYWHEEL SHIELD & MOTOR PLATE:** Modifications are not permitted on SFI rated flywheel shields or liners. SFI rated units must recertify by manufacturers timelines. All units must use manufacturers recommendations per application using high strength rated hardware. Any plate mounted between the engine and flywheel shield not to exceed ½ inch thickness. The motor plate opening for the crankshaft flange can be no bigger than that necessary than 1 inch. Processes, including welding, that can structurally weaken the material are prohibited unless performed by the manufacturer with recertification. Vehicles 11.99 or quicker quarter mile and using a clutch must be equipped with an SFI Spec 6.1 or 6.3 bellhousing and motor plate using 3/8 grade 8 bolts or high strength studs above the crank centerline. Motor plate must use at least eight 3/8" diameter grade 8 bolts or high strength steel alloy studs and nuts below the centerline of the crank to

the bellhousing. OEM style rear engine boxer engine cars are not required to have a shield when the engines are normally aspirated and gasoline burning.

**FRAME:** Welding on chromoly must be done by accepted TIG process. Mild steel welding may be done by MIG or TIG process. Welds must be free of slag, porosity and contamination. Grinding post-weld not permitted. Butt-welds must have visible reinforcement or visible internal sleeve with rosettes.

**FUEL:** Commercially available gasoline/racing fuel, race fuel concentrate, octane boosters, methanol, E-85 and diesel permitted.

**FUEL INJECTION:** Based on class requirements, OEM or aftermarket electronic fuel injection systems permitted. Must be a closed and OEM style system and monitor engine functions and not wheel or driveshaft speed, acceleration measurements, torque management, launch control or traction control.

**FUEL LINES:** Anything containing or transferring fuel should be completely isolated from the driver's compartment by a firewall and completely sealed to prevent any fluid from entering the driver's compartment. All lines crossing the throw of the flywheel must be protected 8 inches on each side in 1/8 inch steel tubing. All lines should be properly protected from supercharger drive assemblies. No lines can run inside driveshaft tunnel. Carbureted or mechanically injected vehicles with mechanical fuel pumps must have a manual fuel-shutoff valve on the main feed line within easy reach of driver. Bare rubber hose should be used sparingly for short run connections only.

**FUEL SYSTEMS:** Fuel blocks must be mounted at least 6 inches in front of the bellhousing. Fuel system components must not be mounted on the firewall besides regulator, in which case should be as far from bellhousing area as possible.

**FUEL TANK:** Must be mounted below the fender well on full bodied entries and below the top of the rear tires on all other applications. .032" aluminum or .024" steel must be used in front of and below tank to enclose tank so that it is sealed off from the driver compartment. Front mounted cells must be protected by at least 1-1/4 inch .058 chromoly or .118 mild steel tubing if mounted outside of steel body or frame. Sealing or locking gas caps mandatory. Non-metallic tanks or cells must be installed with an electrical ground connected to the frame. Tank must be vented to outside of car.

**GROUND CLEARANCE:** All vehicles must have enough clearance to prevent interference with the timing system functions. A minimum of 3 inches must be kept from the front end to the front spindle and 2" for the remainder of the car. Exceptions for oil pan, diaper, header collectors or wheelie bars may be made if they do not interfere with timing.

**HARMONIC DAMPER/BALANCER:** 6.49 or quicker eighth mile or 10.99 or quicker quarter mile requires a SFI 18.1 damper. All friction fit harmonic balancers must have such pulleys or accessories installed and bolted to retain balancer.

**HEAD REST:** Anywhere the drivers helmet could come in contact with a roll bar or roll cage in a rearward direction a padded head protector must be used within 4 inches of the drivers helmet. Padded roll bars or cage components do not qualify unless less than 4 inches.

**HELMET:** Must meet SNELL or SFI specifications. Snell SN, SA, M, or K rated helmet with the appropriate certification decal visible inside the helmet as per individual class requirements required. All open entries must use a full-face unit. Modifications to helmet/visor/shield are prohibited. Spec 31.1 - SNELL SA, open-face. Spec 31.2 - SNELL SA, full-face. Spec 41.1 - SNELL M, open-face. Spec 41.2 - SNELL M, full-face.



**MADE IN THE USA!**

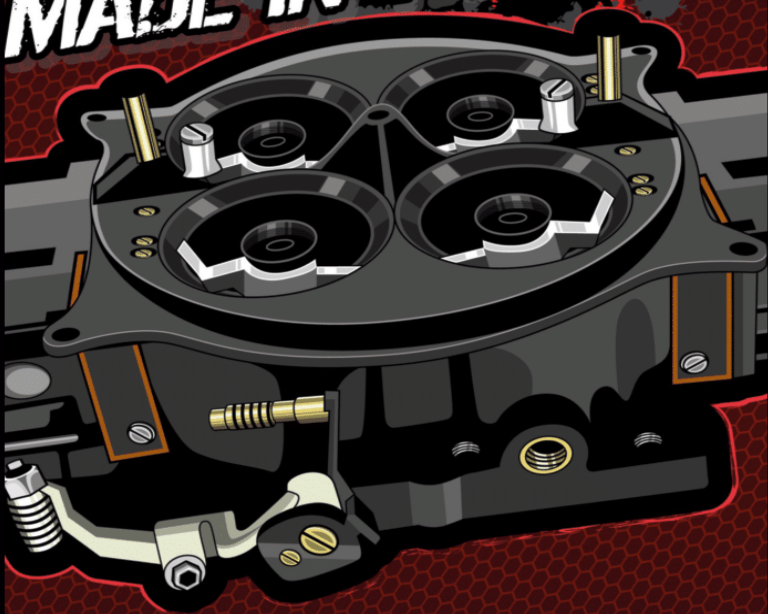

**419-855-3073**

**apdracing.com**

**apdcarbs@gmail.com**

**3025 N Genoa Clay Center Rd.  
Genoa, OH 43430**

*Official Carb Of*





**IGNITION:** Ignition systems or accessories that use multi-point rev limiter or rate of acceleration limiter are strictly prohibited. Examples are MSD 7531,7561 and 7761. Ignition boxes and components may not be altered from the manufacturers factory specifications. Vehicles without a traditional ignition switch must use an easy to reach and easily identified ignition kill switch.

**JACK STANDS:** Locking metal jack stands must be properly used any time a vehicle is lifted.

**LICENSE:** It is recommended that every driver participating in the sport of drag racing hold a valid license in order to obtain the insurance benefits during the dangerous activity. All drivers at any WDRA track, regardless of license, must hold a current and valid state or provincial driver's license. All drivers running 9.99 quarter mile or 6.49 eighth mile or quicker and all Junior Dragster drivers must have a current and valid WDRA License.

*NEW license:* 0-9.99 quarter mile or 6.49 eighth mile without a previously held Competition License will be required to make a minimum of five (5) runs under the observation of a WDRA official, a WDRA Certified Track Safety Inspector or WDRA Sanctioned Track Operator. The required solo passes include one moderate pass, two half passes, and two full passes. Parachute must be deployed on the full passes.

*PRO license:* WDRA will accept a lateral transfer of a valid professional category license to the equivalent WDRA license level.

*UPGRADE license:* Required to make three runs; one moderate run and two at a speed representative of the class applied for.

*INACTIVE license:* Required to make 2 complete single passes to reactivate the license and be permitted to compete in eliminations. An inactive license is defined as any racing member that has not utilized their competition license in 3 calendar years.

**NEW VEHICLES:** WDRA reserves the right to require a competitor to make one solo moderate (shake down) pass on an untested (new) vehicle, prior to making an official run.

Drivers may compete slower than their license level, but not faster. Dragster classification includes roadsters and altered and these as well and full bodied designations are designed to assure driver safety in vehicle types. A dragster, altered or roadster is considered an "open bodied car", not a "full bodied" car. Competitor must purchase a competition number for each class they wish to compete.

CLASS 1: (ET 0-7.99 quarter mile; 0-5.49 eighth mile)

CLASS 2: (ET 8.00 -8.99 quarter mile; 5.50-5.99 eighth mile)

CLASS 3: (ET 9.00-9.99 quarter mile; 6.00-6.49 eighth mile)

CLASS 4: (ET 10.00 -11.99 quarter mile; 6.50-7.49 eighth mile)

CLASS 5: (ET 12.00 & Slower quarter mile; 7.50 & Slower eighth mile)

CLASS JD: Junior Dragsters

CLASS TR: Teen Racing

CLASS EXHIBITION: Professional Class, Jets, Wheelstanders

**LIQUID OVERFLOW:** All cooling systems and any liquid system which requires venting and overflow capabilities must use a catch-can with a minimum capacity of 1 pint minimum.

**MASTER ELECTRICAL CUTOFF:** If battery is relocated or if guidelines require it, a master electrical kill switch is required and must be located on the rear of the vehicle. Switch must break the positive side battery supply when activated. All switches must be clearly labeled as to function and direction of throw from outside the vehicle and those with push-pull activation must be deactivated after pushed. Aftermarket kill switches with removeable or plastic handles are not acceptable.

**NEUTRAL SAFETY SWITCH:** Required. Must function to prevent the engine from starting while the transmission is in any drive gear.

**NITROUS OXIDE SYSTEM:** Commercially available systems permitted. Bottle(s) must be stamped with an 1,800 lb. rating and permanently mounted. Hoses from bottle(s) to solenoid must be high-pressure steel-braided or accepted hoses. Commercially available, thermostatically controlled, blanket-type warmer accepted. The use of a torch or any other external heating methods of bottle prohibited. Storage within drivers compartment may only be done with the use of a relief valve and vent to outside the drivers compartment. All systems and components must be installed per the manufacturers recommended practices.

**OIL:** No oil may be used with the intent of producing power. No oxygen bearing or power enhancing additives are permitted.

**OIL PRESSURE LINE:** Metal or steel braided 3/16" ID

**PARACHUTE:** Required at 150 mph or faster quarter mile or 125 mph or faster eighth mile. 200 mph quarter mile vehicles must have two parachutes with independent mounting brackets and one release handle. Minimum 3/8" grade 8 sleeved bolt must be used. Shroud line mounting brackets must be minimum .090" steel. Safety pins should be red flagged and removed prior to staging.

**PRESSURIZED BOTTLES:** Must be approved and labeled with minimum DOT rating of 1,800 lbs.

**DRIVER PROTECTIVE GEAR:** Elapsed Time Specific Rules will designate required safety gear per ET. Where SFI specifications are required for jacket, pants, gloves, boots, shoes, head sock or arm restraints, units must be SFI tagged and have no holes or excessive wear. Where a neck collar is required, a Head and Neck Restraint System may be used with or without neck collar. **If no specific requirement is stated then the minimum requirements are full length pants, short sleeve or long sleeve shirt, closed toes shoes and socks. No Shorts, no bare legs, no tank tops, no sandals. Nylon or flannel pants are prohibited.**

**ROLL BARS:** Roll bar must be padded anywhere driver's helmet may contact it while in driving position. Adequate padding must have minimum 1/4-inch compression or meet SFI Spec 45.1. All cars running 9.99 (\*6.39) or quicker, SFI Spec 45.1 mandatory. Roll bars must be within 6 inches of the rear, or side, of the driver's head, extend in height at least 3 inches above the driver's helmet with driver in normal driving position or be within 1 inch of the roof/headliner in the area above the driver's helmet, and be at least as wide as the driver's shoulders or within 1 inch of the driver's door. Roll bar must be adequately supported or cross-braced to prevent forward or lateral collapse. Rear braces must be of the same diameter and wall thickness as the roll bar and intersect with the roll bar at a point not more than 5 inches from the top of the roll bar. Crossbar and rear braces must be welded to main hoop. Sidebar must be included on driver's side and must pass the driver at a point midway between the shoulder and elbow. Swing-out sidebar permitted. All roll bars must have in their construction a cross bar for seat bracing and as the shoulder harness attachment point; cross bar must be installed no more than 4 inches below, and not above, the driver's shoulders or to side bar. All vehicles with OEM frame must have roll bar welded or bolted to frame; installation of frame connectors on unibody cars does not constitute a frame; therefore it is not necessary to have the roll bar attached to the frame. Unibody cars with stock floor and firewall (wheeltubs permitted) may attach roll bar with 6-inch x 6-inch x .125-inch steel plates on top and bottom of floor bolted together with at least four 3/8-inch bolts and nuts, or weld main hoop to rocker sill area with .125-inch reinforcing plates, with plates welded completely. Also, the roll bar may be welded to frame connectors that are fully welded in place and are 1 5/8 inches x .118-inch MS or .083-inch CM round and/or 2 inch x 2 inch x .058 MS or CM rectangular. All 4130 chromoly or Docol R8 tube welding must be done by approved TIG heliarc process; mild steel welding must be done by approved MIG wire feed or approved TIG heliarc process. Welding must be free of slag and porosity. Any grinding of welds prohibited. See illustration.

**PRO**

# GRAPHIC INK



- Wraps and Partial wraps
- Custom paint design artwork
- Bulk Stickers
- Name and Number sets
- Custom Banners for sponsors, Parties, race teams and more
- T-Shirts
- Hats
- Custom Fuel Jugs
- Aluminum Signs of all sizes, Reserved Pit Parking Signs No Parking, Garage signs and more
- Special Discount for all WDRA members 15% off



**724-461-4941**

**PROGRAPHICINK.COM**

## ROLL BAR

(10.00 - 11.49 (\*6.50 - 7.35) seconds e.t. and slower)

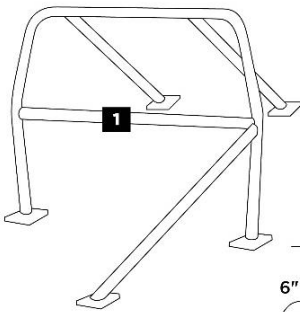

| TUBING CODE |       |      |      |
|-------------|-------|------|------|
|             | OD    | CM   | MS   |
| 1           | 1 1/4 | .065 | .118 |
| All Other   | 1 3/4 | .083 | .118 |

CM = Chromoly  
MS = Mild Steel

- Cars with OEM frame must have roll bar attached to frame.
- Other no frame attachments use 6" square 1/8" steel plates on top and bottom of floor with (4) 3/8" bolts.



**ROLL CAGE:** (8.50 and slower) Chassis certifications are mandatory on all entries running 9.00 or quicker quarter mile or 6.00 or quicker eighth mile or on any vehicle that exceeds 150 mph. All roll cage structures to be designed in an attempt to protect the driver from any angle. In an open bodied car, the helmet must sit at least 3 inches behind the front hoop. Care must be taken to prevent the drivers legs from exiting the vehicle when structures do not include protection above the legs. Front engine dragsters require that a straight-edge adjoining any two components not intersect the drivers seat or containment devices and additional uprights at no more than 30 degrees from vertical must be added to remedy. The drivers helmet must sit forward of the main hoop in all closed bodied entries. Additionally, roll cage must be padded anywhere the driver's helmet may contact it while in the driving position. The side bar (door bar) must pass the driver midway between the shoulder and elbow. All roll cages require a bar for seat bracing and shoulder harness installation and must be at or up to 4 inches below the drivers shoulders and may not attach to side bar (door bar.) All door cars where frame rail is inboard of the drivers seat must have a sill (rocker) bar intersecting the front and rear of cage. Sill must be 1-5/8" OD x .083 CM, or 1-5/8" OD x .118 MS or 2"x2" x .058 box tubing. Frame rails may be a minimum of 1 5/8 x .083 CM or .118 MS or 2 x 2 x .058 CM or MS. Mild steel may be welded by wire feed or TIG. Chromoly or Docol R8 must be welded by TIG. All welds must be free of slag and porosity and finished welds may not be ground.

Swing out bars are permitted on OEM full bodied entries running 8.50 and slower. They must be designed as follows: 1 5/8 diameter x .083 CM or .118 MS connected with a minimum of 3/8 bolts or pins affixed in double shear. Clevis or sliding sleeve connections permitted. All male brackets must be a minimum of 1/8" with corresponding female bracket being 1/4". Sliding sleeves must have a minimum of 2" engagement at the connection. Chrome plating of roll cage prohibited on all entries running 7.50 or quicker 1/4 mile, or on entries that want a certification that is within that respective SFI specs E.T. range. A dash bar is mandatory if the OEM firewall has been modified in excess of 1 square foot for transmission removal. Minimum specifications: 1-1/4" x .058 CM, or 1-1/4" x .118 MS. Head guards or helmet bars must be installed on all entries presented for certification under SFI

**FULL-BODIED CARS**  
(8.50 (\*5.25) seconds e.t. and slower)

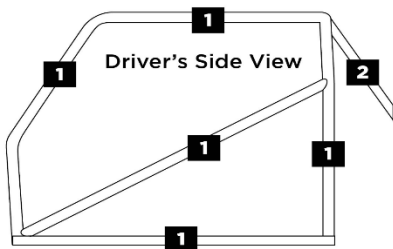

| TUBING CODE |       |      |      |
|-------------|-------|------|------|
|             | O.D.  | CM   | MS   |
| 1           | 1 5/8 | .083 | .118 |
| 2           | 1 1/2 | .058 | .118 |
| 3           | 1 1/4 | .065 | .118 |
| 4           | 1 1/4 | .058 | .118 |

CM = 4130 Chromoly or Docol R8  
MS = Mild Steel

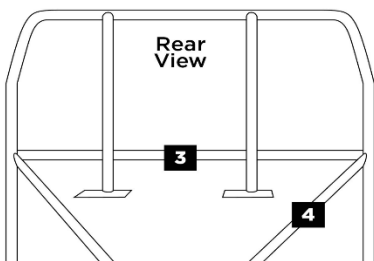

**REAR-ENGINE DRAGSTER**  
(10.00 (\*6.40) seconds e.t. and slower)

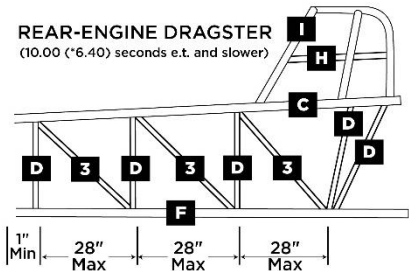

All dimensions apply to driver's compartment only

**Bottom View**

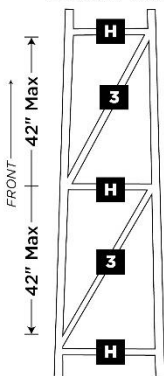

**Front Views**

(Dragster: Rear Engine)

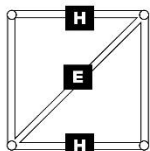

OPTION 1

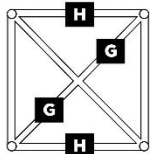

OPTION 2

| RED, FED, ALTERED, AND FUNNY CAR TUBING CODE |       |                      |            |
|--|-------|----------------------|------------|
|  | O.D.  | Chromoly or Docol R8 | Mild Steel |
| A  | 1 1/2 | .065                 | .118       |
| B  | 1 5/8 | .065                 | .118       |
| C  | 1 3/8 | .058                 | .118       |
| D  | 1 1/4 | .058                 | .118       |
|  | 1 1/8 | .065                 | .118       |
| E  | 3/4   | .058                 | .118       |
|  | 1     | .049                 | .118       |
| F  | 1 1/4 | .058                 | .118       |
|  | 1 3/8 | .049                 | .118       |
| G  | 5/8   | .058                 | .118       |
| H  | 1     | .058                 | .118       |
| I  | 1 1/4 | .049                 | .118       |
| 3  | 3/4   | .058                 | .118       |

specifications 2.2, 2.3, 2.4, 2.5, 2.6, 2.7, 10.1 and 10.2. The minimum specification is 1" X .058 CM. See appropriate SFI specification for all full bodied entries 8.49 or quicker quarter mile.

**SEATS:** Drivers seat, as well as any passengers where allowed, must be constructed and secured in a manner which will not let it shift during collision. After market seats must be braced and supported and may be made from carbon fiber, aluminum, fiberglass or double-layer plastic. In all vehicles with roll bars or cages, aftermarket seats must also brace to the rear cross bar.

**STARTERS:** Vehicles must be self-starting; with the exception of some exhibition entries. Push starts prohibited. Starters may never be used to move or stage vehicle.

**STEERING:** Traditional OEM style steering systems are the only types allowed in competition. All steering boxes, sectors and shaft mounts must be mounted to frame and may not be mounted to the bell housing or any other drivetrain component. Drag link and tie rod ends must use fully locking or keyed hardware. All welded parts must have additional visible reinforcement. Rod ends must be 3/8 inch shank or bigger and must incorporate pull-through protection via washer and must be of aircraft quality or better.

**SUPERCHARGERS:** Over drive may not exceed 70 percent. Maximum size permitted 14-71; 22 1/4" maximum rotor case length; 11 1/4-inch case width, 19-inch rotor length; maximum rotor diameter: 5.840 inches including fixed stripping. The case must be one piece with removable front and rear bearing end plates; rotor must be contained within one-piece case. Aluminum studs connecting supercharger to manifold mandatory on all non-OEM applications. All manufacturers recommendations for burst panels and restraints must be adhered to. High Helix type must adhere to the same rules with helix angle not to exceed 6.5 degrees per inch or 123.5 degrees total over 19-inch maximum rotor length. **SFI spec 14.1 restraint system mandatory on Roots type supercharger when alcohol is used. Belt guard or oil/fuel line guard must be used where lines pass by the belt.**

**SUSPENSION:** OEM type suspension required on street driven cars. No hard mounting of axles.

**THROTTLES:** Positive stops and dual return springs directly on throttle plate arm required on all systems. All efforts must be made to ensure throttle linkage does not bind, over-center or hang open. Foot controlled throttles required unless using licensed hand controls. Cable systems are allowed in place of linkage.

**TRACTION CONTROL** Any type of traction-control device, electronic or mechanical, is prohibited during bracket races unless facility explicitly allows. A traction-control device is any unit or system that uses live data to control functions of the vehicle, such as tire slip, which are not controlled by the driver. These devices are, but not limited to, timing control based on wheel, driveline, or engine acceleration, braking control, throttle control, tire-shake meters, vertical acceleration meters, misfire control, stutter box, relays, and/or rpm-activated chips

**TRANSMISSION BRAKE:** Only one switch allowed per vehicle per class rules. Must be a traditional style switch and may not be hydraulic or pneumatic in function.

**TWO-STEP:** See ET based rules and regulations.

**TRANSMISSION:** Neutral safety switches and reverse lockout functions must be installed and functioning in all automatic transmissions.

**TRANSMISSION SHIELD:** See ET based rules and regulations.



*Members  
Get*

**10%  
OFF**

# **TECHNOCRAFT**

QUALITY ALUMINUM CABINETS

*Racer  
Owned!*

**Overhead Cabinets  
Base Cabinets  
Toolboxes  
Wheel Well Cabinets  
Closets & MORE!**



**Custom Sizes Available  
No Extra Charge**

**931-379-5500  
[www.trailercabinets.com](http://www.trailercabinets.com)**

**WHEELS & TIRES:** Wheels must use all available lugs. Pull through valve stems are only allowed on vehicles slower than 7.48 eight mile or 11.99 quarter mile and metal screw in style must be used for those faster. If OEM style wheel nuts are used, wheel studs must project through lug nut.

If aftermarket wheel and recessed shoulder nut are used, stud threads must project through wheel. No hubcaps or wheel covers may be used. All street type DOT tires must have at least 1/16 of tread depth. All dragster fronts must use a tire specifically designed for automobile racing.

**WINDOW NET:** If a roll cage is necessary, an SFI 27.1 window net is required. Installation must be per manufacturers instructions with permanent fastening at the bottom.

**WINDOWS/WINDSCREENS:** Full bodied cars must have windshield. Must be OEM or 1/8 inch thick Lexan, Plexiglas, safety glass or other shatterproof material. All chopped vehicles must have window openings at least 5 inches high. On all open bodied entries or those permitted without a windshield, a windscreen must be used to protect the driver from any foreign debris or liquid. Windscreen must be fire resistant in nature and must protect the drivers helmet adequately. Recommended size for altered and roadsters 5x12 inches.

## **CHASSIS CERTIFICATION AND INSPECTION**

Chassis inspection and certification is a service offered by WDRA, in express consideration of and subject at all times to the following terms and conditions, in WDRA's sole and absolute discretion. By submitting a chassis for inspection, owning or driving a vehicle which has had its chassis certified, or otherwise participating in the sport of drag racing, all participants acknowledge and agree to the following terms and conditions regarding chassis inspection and certification. Whether or not the participant or an otherwise affected party signs any documents in connection with chassis inspection or certification, the participant or otherwise affected party agrees to the terms set forth below and each is hereby put on notice of such terms and makes such agreement either by receiving this rulebook or participating in the sport, or both. The foregoing and following terms govern all WDRA chassis inspections:

1. Participant will not operate a vehicle or allow it to be operated at a weight in excess of the "Maximum Permitted Weight" or at an elapsed time less than the "Quickest Permitted E.T." for which the chassis is certified, or otherwise not in compliance with any WDRA rule, regulation or agreement.

2. If at any time a vehicle does not comply with current WDRA Chassis Certification requirements, it will not be operated in any manner at a WDRA member track until required repairs have been completed and certification or recertification is obtained.

3. WDRA Chassis Certification and/or inspection (a) is undertaken for the limited purpose of allowing WDRA to satisfy itself that the chassis, at the time of inspection appears to comply with WDRA rules governing chassis construction, as this is a requirement for the vehicle being allowed to operate at WDRA or WDRA Member track events (including private test sessions); (b) does not constitute a certification for use at any location other than an WDRA member track; (c) does not constitute a warranty or guaranty of any kind, including without limitation a warranty or guarantee that the vehicle, including its chassis, is free of defects, latent or otherwise, or that the vehicle as finally constituted is or will be safe to operate; and (d) that the inspection is limited to the chassis only.

4. Drag racing is a dangerous sport. There is no such thing as a safe drag race. Drag racing always carries with it the risk of serious injury or death in any number of ways. This risk will always exist no matter how much everyone connected with drag racing tries to make our sport safer. Although WDRA works to promote and enhance the safety of the sport, there are no guarantees that such safety measures will guarantee or ensure safety. The participant always has the responsibility for the participant's own safety, and by participating in drag racing, the participant accepts all risks of injury, whether due to negligence, vehicle failure, or otherwise.

If at any time a participant does not accept these risks, the participant agrees not to participate in drag racing.

5. No liability or duty to third parties, express or implied, is undertaken or assumed by WDRA or its Member Tracks regarding any Chassis Certification or any use of a vehicle that contains a certified chassis.

6. Responsibility for the proper construction, rule compliance, and performance of a vehicle and its chassis rests with the participant at all times. If injury or death to participant or another person results from operation of the vehicle, participant releases, waives and indemnifies WDRA from and against any resulting claim against WDRA or WDRA member tracks.



# TVC

Total Venue Concepts

Your Single Source In  
Race Track Project Management

**TVC**

**PROUDLY**

**OFFERS:**

- Racetrack Prep & Maintenance
- Concrete Surface Repairs
  - Grinding & Texturing
  - Racetrack Resurfacing
- Equipment Fabrication
- Equipment Rental & Sales
- Management & Consulting
  - Event Facility Design
  - Race Event Staffing
  - & Much More



Available 24/7  
Worldwide



Call or Text  
(419) 677-3023

Email Kurt Johnson  
contact@TotalVenueConcepts.com

More Info: [TotalVenueConcepts.com](http://TotalVenueConcepts.com)

## GENERAL RACE REGULATIONS

Your local track may have different race procedures for their weekly program, however all safety related rules in this rulebook may not be changed and must be followed at all times. These rules and regulations are intended as a guide for the conduct of the sport and are in no way a guarantee against injury or death to participants or spectators. These rules express no implied warranty or safety in any way. The procedures and regulations set in this book shall be followed at all WDRA managed events. Interpretation will be made by the WDRA or facility Race Director. For the following guidelines both shall be referred to as the "Official." Their decision shall be final.

**ASSUMPTION OF RISK:** Drag racing is a dangerous sport that can result in serious injury or death. Participation in all aspects of the sport is voluntary. The ultimate responsibility for participant and vehicle safety lies with the participant, vehicle owner, driver and crew members. The participant agrees that by entering and participating in an event, the participant has had the opportunity to inspect the event site and acknowledges that the event site is safe and suitable for racing. The participant agrees that he or she will not participate in the event if he or she does not believe that the event site is safe and suitable for racing. The participant further agrees that by entering and participating in an event, the participant has had the opportunity to ascertain the staff and equipment on hand, including without limitation number and location of personnel and number and type of rescue equipment, and acknowledges that the staff and equipment are adequate and suitable for racing. The participant agrees that he or she will not participate in the event if he or she does not believe that the staff and equipment are safe and suitable for racing. The participant also acknowledges that by participating in the event, the participant may suffer bodily injury or death or loss or damage to property. The participant further acknowledges that the participant has voluntarily assumed the risk of bodily injury or death or loss or damage to property and waives any claims for bodily injury or death or loss or damage to property against WDRA, its directors, officers, employees and agents, event officials, event sponsors, racetrack operators and other participants; discharges such persons and entities from responsibility for such losses; and covenants not to sue such persons and entities for bodily injury or death or loss or damage to property.

**AUTHORITY:** The WDRA or facility management (Officials) reserve the right to refuse anyone entry to any event.

**BURNOUTS:** Only under the approval of official may vehicles be held or guided in the water box. Only vehicles without front brakes may burnout across the starting line under power. Warnings may be made by officials. Upon a vehicle stalling or breaking during the burnout process, the officials may push a vehicle back or instruct crew to assist. Only if the vehicle can be ready to race in an appropriate timeframe may the starter allow them to run. Under no circumstances may a vehicle turn around and return to the starting line.

**CAR NUMBERS:** Permanent vinyl or painted numbers a minimum of 4" high recommended for all vehicles. WDRA competition number must be clearly visible on all appropriate sides of your vehicle. Additional numbers they must be covered prior to competition.

**DIAL-INS:** May not be changed after the vehicle has left the head of staging, ready line or designated area unless approved by official. Scoreboards or dial-in boards at any facility stand as the drivers verification and acceptance of run. Any vehicle lighting the stage bulb on an incorrect dial-in accepts it.

**DUAL INFRACTIONS:** Please see Ranking Grounds for disqualification.

**LANE CALLS:** Only one call to staging area is required. After a reasonable time any vehicle not in the staging lanes may be subject to disqualification. Vehicles left unattended in the staging lanes may be disqualified.



## **WE CREATE AMERICAN PRODUCTS**

Whether you're hauling ass across the race track or hauling asses in a trailer, we have you covered. All our products are made in America, by men and women who make a living by supporting every type of American in the diesel industry. Because we know you have places to be and records to beat.

**AMERICAN PRODUCTS.**

**AMERICAN WORKERS.**

**AMERICAN CRAFTSMANSHIP.**



**LANE CROSSING/BOUNDARY CROSSING:** Crossing and potential disqualification will be determined by any part of a tire touches a painted boundary line. When multiple lines are used, the closest adjacent line to each lane will be used. Any timing equipment, track barricade, reflector blocks, etc. will also be grounds for disqualification. Decorative painting surrounding tree and starting line may not be used to determine boundary crossing. On bye-runs or broken solos, lane boundary crossings will not be enforced.

**PASSENGERS:** Passengers are only allowed in vehicles running 8.75 eighth mile or 13.99 quarter mile or slower and must be 16 years of age or older. All minors must sign facilities minor waiver. All passengers are required to use the same safety guidelines as driver per vehicle.

**PUBLICITY:** By entering any WDRA or WDRA facility event, all participants agree as follows: 1. All rights to use still or audio-visual images, or sounds from the events for any purpose, such as advertising, promotion, exhibition, and commercial exploitation of the event, the participants and vehicles entered in the event, and their activities at the site of the event before, during, and after the event and reasonably related to the event, are reserved to WDRA or Facility. 2. Participants hereby grant WDRA full and unconditional permission to take still or motion pictures and any other recordings of participants and vehicle participation in the event and their activities at the site of the event and the exclusive, worldwide and perpetual rights to use any and all recordings or portions thereof, together with their names, likenesses, and biographies, and the names, likeness, and data of, or relating to, their entered vehicles and any other information concerning their participation as collected or generated by WDRA for any purpose, in any form, on any platform, on any media by any and all means now known or hereafter developed. 3. Participants agree that, without the prior written consent of WDRA, they shall not take any still or motion pictures or make any audio or audio-visual recording of the event, participants therein, or activities at the site of the event for use other than personal, in-home use of the participant, or cause or permit others to do so or to use any pictures or recording or event related data compilations from the event. 4. Participants agree that, without the prior written consent of WDRA, they shall not offer for sale, sell, give away, or otherwise distribute at the site of the event any token, any souvenir, any product, or thing of value, or permit others to do so. 5. Participants acknowledge WDRA's sole right to license, publish, distribute and exploit any data or statistics compiled relating to the events or their participation in the events, whether generated by using the WDRA scoring and timing systems or otherwise, in any form, live or in a compilation, in perpetuity, however, WDRA grants permission for participants to use their own data for non-commercial purposes.

**REFUND POLICY:** There will be no refund of the Car and Driver Entry at any WDRA operated event unless the vehicle does not pass technical inspection or it breaks prior to making the first run.

**REINSTATEMENT:** There is no reinstatement of a losing vehicle even if the winning vehicle is unable to return.

**RE-RUNS:** Re-runs are not dictated by the racer, even if compliance with opponent is granted. Failure to rerun when instructed will result in disqualification. Cases where incremental or MPH times have discrepancies are not cases for re-runs as the finish line ET is the only guaranteed time. Interference from competition, track surface and preparation may not constitute a re-run. Lane choice and dial-ins for re-runs may only be changed at the discretion of the WDRA or facility official.

**STAGING:** Vehicles failing to start when signaled by an official will be given 30 seconds to start or may be disqualified. If a vehicle stalls, the officials have the authority to disqualify the competitor if it causes a risk.

The final motion of starting line staging must be forward from prestage to stage, with the front wheels, under the vehicle's own power. Staging with vehicles starter is not permitted.

Not staging when instructed, over staging while autostart is engaged or leaving the starting line before the timing system is activated may result in disqualification and no elapsed time.

Staging deep, or out of the prestage beam, is the responsibility of the driver. Deep staging techniques do NOT require any allocations from the starter or timing system.

Some events or facilities may require courtesy staging. Each driver must prestage before either may stage. In these cases deep stagers may be required to light both prestage and stage beams as “prestaged.”

**STARTING SYSTEM:** The rollout at all WDRA events will be 11 1/2” for both pre-stage and stage with 7” between the beams as measured by a 22-inch dragster front.

“Staged Minimum” is the amount of time the tire must be seen the stage beam to begin the Auto Start process.

“Staged to Start” is the amount of time both vehicle’s tires must be seen by each stage beam to begin the tree activation process.

Time Out is the amount of time from when one car is pre-staged and staged and the other car is only pre-staged until the tree is activated, fired and the non-staged competitor potentially receives a red light.

**Recommended Autostart Settings in seconds:**

|                            | <b>Staged Minimum</b> | <b>Staged to Start</b> | <b>Time Out</b> |
|----------------------------|-----------------------|------------------------|-----------------|
| <b>ET / Bracket Finals</b> | <b>0.6</b>            | <b>0.9</b>             | <b>10</b>       |
| <b>Junior Dragster</b>     | <b>1.0</b>            | <b>0.8</b>             | <b>15</b>       |
| <b>Exhibition Classes</b>  | <b>0.6</b>            | <b>0.4</b>             | <b>7</b>        |

AT WDRA operated events, if both vehicles leave before the timing system initiates the race, the driver leaving first will be disqualified. If the race director or starter is unable to determine who left first, both competitors will be disqualified. If this happens during a final round the pair will re-run.

**TECHNICAL INSPECTION:** By conducting a technical inspection, WDRA and its member tracks make no representations, warranties, or assurances that a technical inspection, including the review of any written information or data, will do any or all of the following:

- 1) Detect every or any problem with a vehicle or a participant’s personal protective equipment or
- 2) Detect every problem with rule compliance; or
- 3) Prevent injury, death or property damage.

The participant agrees that the participant bears the ultimate responsibility at all times to ensure the safety of their vehicle, equipment and personal protective equipment, and compliance with all then current WDRA rules, regulations, and agreements, including but not limited to those contained in this rulebook. The participant agrees that they are in the best position to know about the construction and operation of their vehicle, the vehicle’s equipment and personal protective equipment, and whether there has been compliance with all WDRA rules, regulations and agreements, including but not limited to those contained in the rulebook. In the case of technical violations, the participant acknowledges, understands and agrees that they are charged with full knowledge of every component in, on or of their vehicle and personal protective equipment, and that even if a third party has caused the participant’s vehicle, equipment or personal protective equipment to be noncompliant, the participant will still be responsible for and charged with any applicable violation and sanction. Disclaiming knowledge of the particular part, equipment, or personal protective equipment, or disclaiming knowledge of the rule or rules, or disclaiming responsibility for the actions of the third party, will not be defenses to any violation or any sanction.

**VIDEO REPLAY:** There is no video replay rule. Any captured video by crew, spectators or track is not admissible in determining timing system or

starting line discrepancies. Although compelling, rolling shutter discrepancies, shutter speed and timing and inconsistent lighting flicker can cause incorrect assumptions while replaying video.

**WARMUP:** Vehicles must have a qualified driver at the controls prior to starting and be entirely within the confines or the participants designated pit area.

#### **PIT AREA RULES**

**DRIVER RESPONSIBILITY:** Drivers will be held accountable for the enforcement of all rules in this section.

**GENERATORS:** Generators may not exhaust into adjacent pit spaces. It is recommended that generators exhaust upward. If your generator exhausts near someone else's pit space it must not provide an unsafe or inconvenient issue. Portable generators must be placed within designated pit area or in an unused area not used for pitting.

**PETS:** It is recommended that all pets be restrained on a leash or tethered at all times. Failure to comply may result in disqualification or litigation if your pet harms another pet or person at any WDRA sanctioned event or member track.

**PIT VEHICLES:** Must be operated in a responsible manner. Separate vehicles carrying only pit vehicles may not be permitted under some circumstances. Pit vehicle operators must have a valid state or provincial driver's license. All crew members, passengers, etc., must be in a seated position completely inside all vehicles. Crew members hanging on, standing or seated in unsafe places in or on the tow vehicle is prohibited.

#### **DRIVER CONDUCT**

Any actions by drivers, crew or participants of any kind deemed unsafe, unfit or unbecoming may be refused service by the WDRA or Facility.

#### **DISQUALIFICATIONS AND SUSPENSIONS**

The Race Director present at the event has the authority to disqualify any group, vehicle or participant from the event. Disqualified participants, organizations or manufacturers shall have no legal or equitable right of action against officials of WDRA for publicizing notice of disqualification. In the event a person files litigation against the WDRA or one of its sanctioned facilities, that person, crew or family member will be suspended from competition and from entering WDRA sanctioned facilities until a settlement can be reached.

#### **INTERPRETATION AND COMPLIANCE TO RULES AND REGULATIONS**

The Rules and/or Regulations set forth herein are designed to establish minimum acceptable requirements for events and the interpretation of all rules and regulations shall be made solely by WDRA. In any instance where a rule has to be interpreted, the race director's decision is final in all cases. These rules shall govern the condition of all WDRA sanctioned events and by participating in these events, all WDRA members are deemed to have complied with these rules.

**LOSS OF INSURANCE COVERAGE:** WDRA strongly reminds members and track operators of the importance of following the WDRA rulebook and guidelines designed to protect racer and track insurance coverage. Adhering to rules and competition guidelines as stipulated in the WDRA rulebook and related publications ensures you receive coverage and protection in the event of a racing accident. Examples of non-compliance that may lead to the loss of insurance coverage include:

- A facility failing to have the approved waiver and release forms signed by racers, employees, ambulance crews and anyone in a restricted area.
- A facility failing to witness the waiver and release at the same time the waiver is signed.
- Facilities permitting cars to compete or test without proper license, chassis certification if required or safety equipment as per class requirements.
- Participants not having a license, chassis certification if required or wearing the required safety equipment.
- A junior dragster driver permitted to compete without having a license or competing above the ET limits for their license or class.



Specifications applicable to WDRA Drag Racing, with respective expiration periods. An item with an expiration period must be inspected and recertified at the end of this period before it can be used to qualify at a WDRA event. Specifications are available from the SFI Foundation. [www.sfifoundation.com](http://www.sfifoundation.com) - 858.451.8868

| SPEC   | DESCRIPTION   | EXP     |
|--------|---|---------|
| 1.1    | Replacement Flywheels and Clutch Assemblies   | 2 Years |
| 1.2    | Multiple Disc Clutch Assemblies   | 2 Years |
| 1.5    | Multiple Disc Clutch Ass. for Supercharged, Nitrous and Turbo   | 1 Year  |
| 2.1    | Rear Engine Dragster Roll Cage - 6.29 and quicker   | 2 Years |
| 2.2    | Front Engine Dragster Roll Cage - 6.29 Seconds & Quicker  | 2 Years |
| 2.3    | Rear Engine Dragster Roll Cage - Top Fuel Entries   | 2 Years |
| 2.4    | Front Engine Dragster Roll Cage - 6.30 to 7.49 Seconds  | 2 Years |
| 2.5    | Rear Engine Dragster Roll Cage - 6.30 to 7.49 Seconds   | 2 Years |
| 2.6    | Front Engine Dragster Roll Cage - 7.50 Seconds & Slower   | 3 Years |
| 2.7    | Rear Engine Dragster Roll Cage - 7.50 Seconds & Slower  | 3 Years |
| 3.2A   | Driver Suits/1/3/5  | N/A     |
| 3.2A   | Driver Suits/10/15/20 /25/30  | 5 Years |
| 3.3    | Driver Accessories  | N/A     |
| 4.1    | Automatic Transmission Shields (rigid)  | 5 Years |
| 4.1    | Automatic Transmission Shields (flexible)   | 2 Years |
| 6.2    | Bellhousing for SFI 1.2, 1.3,1.4 &1.5 Clutch Assemblies   | 2 Years |
| 6.3    | Bellhousing for SFI 1.2, 1.3 & 1.4 Clutch Assemblies  | 2 Years |
| 7.1    | Lower Engine Containment Device   | 1 Year  |
| 7.2    | Lower Engine Containment Device   | 5 Years |
| 8.1    | Remote Fuel System Drive Assembly   | N/A     |
| 9.1    | Front Wheel Drive Vehicle Bellhousing Shields   | 5 Years |
| 10.2   | Funny /Altered Car Roll Cage 6.00 to 7.49   | 2 years |
| 10.3   | Funny /Altered Car Roll Cage 7.49 and slower  | 3 years |
| 10.4   | Side Steer Roadster 7.49 and slower   | 3 years |
| 14.1   | Supercharger Restraint Devices  | 2 Years |
| 14.2   | Alcohol Supercharger Restraint Devices  | 2 Years |
| 14.2.1 | Screw-Type Supercharger Restraint Devices   | 2 Years |
| 14.4   | Containment Valve Covers/Valve Cover Shields  | 2 Years |
| 15.1   | Drag Race Drive Wheels  | N/A     |
| 15.2   | Drag Race Front Wheels  | N/A     |
| 15.3   | Drag Race Drive Wheels  | N/A     |
| 15.4   | Drag Race Drive Wheels  | N/A     |
| 16.1   | Driver Restraint Assemblies   | 2 Years |
| 16.5   | Driver Restraint Assemblies   | 2 Years |
| 17.1   | On Board Fire Extinguishing Systems   | N/A     |
| 18.1   | Crankshaft Hub Harmonic Dampers   | N/A     |
| 23.1   | Supercharger Pressure Relief Assemblies   | 2 Years |
| 24.1   | Youth Helmets   | N/A     |
| 25.1   | Full Bodied, Tube Chassis Cage - 7.49 and Quicker; 2,800 Lbs. Max   | 2 Years |
| 25.2   | Full Bodied Car, Tube Chassis Cage - 7.49 and Quicker; 3,200Lbs. Max  | 2 Years |
| 25.3   | Full Bodied Car, Tube Chassis Cage - 6.50 and Slower; 3,600 Lbs. Max  | 2 years |
| 25.4   | Full Bodied Car Tube Chassis Roll Cage - 7.50 -8.49 Seconds; 3,600 Max  | 3 Years |
| 25.5   | Full Bodied Car Stock or Modified/OEM Floor and Firewall with OEM Frame or Uni-Body Construction - 7.50 to 8.49 Seconds; 3,600 Lbs. Maximum   | 3 Years |
| 25.5   | Full Bodied Car Stock/Truck or Modified/OEM Floor and Firewall with OEM Frame or Uni-Body Construction - 7.99 to 8.49 Seconds; 5,000 Lbs. Max | 3 Years |
| 27.1   | Window Nets (Mesh)  | 2 Years |
| 27.1   | Window Nets (Ribbon)  | NA      |
| 28.1   | Fuel Cells  | N/A     |
| 29.1   | Automatic Transmission Flexplates   | 3 Years |
| 30.1   | Automatic Transmission Flexplate Shields  | 5 Years |
| 31.1   | Flame Resistant Open Face Motorsport Helmets (SA)   | N/A     |
| 31.2   | Flame Resistant Closed Face Motorsport Helmets (SA)   | N/A     |
| 37.1   | Roll Cage Nets  | N/A     |
| 38.1   | Head and Neck Restraint System  | N/A     |
| 40.1   | Abrasion Resistant Driver/Rider Suits   | N/A     |
| 41.1   | Open Face Motorsport Helmets SN (M Rating)  | N/A     |
| 41.2   | Closed Face Motorsport Helmets SN (M Rating)  | N/A     |
| 42.1   | Steering Wheel Quick Disconnect/Release   | N/A     |
| 43.1   | Driveshaft  | N/A     |
| 45.1   | Roll Cage Padding   | N/A     |



**REARENDS BUILT FOR RACE OR STREET**

**ISOTROPIC MICROPOLISHING  
OF GEARS AND BEARINGS**

**REAREND HOUSING NARROWING**



**10% Discount for  
WDRA Members**



**TOMMY BORGIA 502-837-1641**

**f KENTUCKY GEARS**



## RANKING GROUNDS FOR DISQUALIFICATION

The HIGHER number, the worst the infraction. When both racers commit an offense, the worse offense is applicable for disqualification. If both the same, the first offense will be applicable for disqualification.

8. Failure to start engine in a timely process to start the race.
7. Not staging with final motion being forward from prestage to stage. (backing into staging beam)
6. Touching strip center line in any situation during a competitive run with the exception of singles.
5. Excessive braking that causes loss of control. If only tire smoke is observed, one warning may be issued at the discretion of race director.
4. Rolling out of staging beams after staging is complete. (over-staging)
3. Redlight or foul start on dual competition run.
2. Running under dial-in. (Breakout)
1. Not crossing the finish line on a competitive run.

## WORLD DRAG RACING ALLIANCE TECHNICAL REFERENCE GUIDE

|                         | 1/4 Mile                             | 0-9.99                                 | 10.00-11.49  | 11.50-13.49 | 13.50& Slower |
|-------------------------|--------------------------------------|--|--------------|-------------|---------------|
|                         | 1/8 Mile                             | 0-6.49                                 | 6.50-7.49    | 7.50-9.00   | 9.00 & Slower |
| Aftermarket Axles       | YES                                  | at 10.99                               | NO           | NO          |               |
| Arm Restraints          | Required on all open bodied vehicles |  |              |             |               |
| Bellhousing SFI 6.1/6.2 | YES                                  | YES                                    | at 11.99     | NO          |               |
| Catch Can               | YES                                  | YES                                    | YES          | YES         |               |
| Chassis Certification   | @9.00                                | @150mph                                | NO           | NO          |               |
| Competition License     | YES                                  | Recommended for all other categories   |              |             |               |
| Driveshaft Loop         | YES                                  | YES                                    | Slicks       | Slicks      |               |
| Fire System Full Bodied | @7.49                                | Extinguisher                           | NO           | NO          |               |
| Flexplate SFI 29.1      | YES                                  | at 135mph                              | NO           | NO          |               |
| Shield SFI 30.1         | YES                                  | at 135mph                              | NO           | NO          |               |
| Flywheel/Clutch SFI 6.1 | YES                                  | YES                                    | NO           | NO          |               |
| Gloves SFI 3.3-1        | 8.49/5.49                            | Open Bodied                            |              |             |               |
| Harmonic Bal. SFI 18.1  | YES                                  | at 10.99                               | NO           | NO          |               |
| Helmet SN /SA/M/K-2015  | YES                                  | YES                                    | YES          | at 13.99    |               |
| Jacket SFI 3.2A-1       | NO                                   | YES                                    | NO           | NO          |               |
| Jacket SFI 3.2A-5       | YES                                  | Open Bodied                            | NO           | NO          |               |
| Master Cut Off Switch   | YES                                  | If battery is relocated for all others |              |             |               |
| Neck Collar SFI 3.3     | @9.00                                | NO                                     | NO           | NO          |               |
| Neutral Safety Switch   | YES                                  | YES                                    | YES          | YES         |               |
| Pants SFI 3.2A-5        | @9.00                                | NO                                     | NO           | NO          |               |
| Parachute               | YES                                  | @150mph                                | NO           | NO          |               |
| Pressurized Bottle DOT  | YES                                  | YES                                    | YES          | YES         |               |
| Roll Bar 6 Point        | NO                                   | YES                                    | Convertibles | NO          |               |
| Roll Cage               | YES                                  | @135mph                                | NO           | NO          |               |
| Taillight               | YES                                  | YES                                    | YES          | YES         |               |
| Trans Reverse Lockout   | YES                                  | YES                                    | YES          | YES         |               |
| Trans Shield SFI 4.1    | YES                                  | @10.99                                 | Recommended  |             |               |
| Window Net              | YES                                  | @135mph                                | NO           | NO          |               |

When you *know* your media  
...it's bound to be **Kingdom!**



As a proud partner of the World Drag Racing Alliance,  
**Kingdom Media Company** is an award-winning,  
full-service digital media, marketing, and advertising agency.  
Experts in brand, Kingdom Media comes fully stocked with  
ice-cold, premium ingredients.



# Unbeatable Value!



- The best selection • Trusted tech • World-famous service
- Fast shipping from locations nationwide • Satisfaction guaranteed

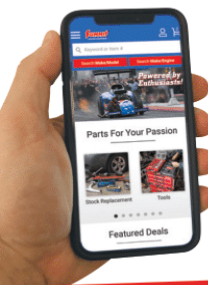

## We're Your Go-Fast Source!

Shop anytime. Use the Summit Racing Mobile App to browse thousands of parts, add items to your cart, check your order status, create wish lists, read and post reviews, access Summit Racing's social media channels, and more.

# The World's Speed Shop<sup>®</sup>



1-800-230-3030  
[SummitRacing.com](http://SummitRacing.com)